



# Slimline®

Technical/Installation Information

# IMPORTANT NOTICE

**READ THIS MANUAL COMPLETELY PRIOR TO BEGINNING THE INSTALLATION OF ANY SL SERIES ROOFING SYSTEM.**

**ALWAYS INSPECT EACH AND EVERY PANEL AND ALL ACCESSORIES BEFORE INSTALLATION. NEVER INSTALL ANY PRODUCT IF ITS QUALITY IS IN QUESTION. NOTIFY ABC IMMEDIATELY IF ANY PRODUCT IS BELIEVED TO BE OUT OF TOLERANCE, SPECIFICATION OR HAS BEEN DAMAGED DURING SHIPMENT.**

**IF THERE IS A CONFLICT BETWEEN PROJECT ERECTION DRAWINGS PROVIDED OR APPROVED BY THE MANUFACTURER AND DETAILS IN THIS MANUAL, PROJECT ERECTION DRAWINGS WILL TAKE PRECEDENCE.**

## Ice Dam Disclaimer

ABC designs its standing seam roofs to meet the load requirements dictated by governing codes and project specifications, including applicable snow loads. However, ABC expressly disclaims responsibility for weathertightness or roof point loading issues or other hazards resulting from ice dam situations. Any time ice and snow can melt on the main body of the roof and refreeze at the eave or in the shadow of an adjacent wall, an ice dam situation may develop. In addition to local climate, ice dam formation is affected by many other factors, including but not limited to, roof insulation R value, roof panel color, interior temperature of building, heater location in building, eave overhangs, parapet walls, shading of building roof areas from adjacent trees, parapets, buildings, etc. These factors are design and maintenance issues and are outside the control of ABC. ABC specifically disclaims any liability for damage due to ice dam formation, although the following issues should be taken into consideration concerning standing seam roofs installed in freezing climates:

- Always use field seamed panels. These machine-folded seams are more durable when subjected to occasional icing.
- Eliminate "cold" eave overhangs and parapet walls from the building design. Roof overhangs outside the heated envelope of the building will tend to be colder than the roof areas over the heated envelope. Simple roof designs are preferred. Parapet walls at the eave allow ice and snow to collect due to shading effects and the lower roof temperatures caused thereby.
- Make sure the interior of the building is adequately insulated and the heating is properly distributed. Inadequate insulation in the roof and/or improper heat distribution causes heat flow through the main body of the roof. On days when the temperature is below freezing, this heat gain can cause ice and snow to melt and refreeze at the eave where the roof is colder.
- Lay out the building to prevent the eaves and other roof areas from being shaded during the winter. This may mean eliminating adjacent trees or reconsidering roof geometries.
- Consider using self-regulating heating cables at the eaves to mitigate the effects of ice dams.
- On building designs using attics, over-insulate the attic floor and provide adequate ventilation in the attic. This will reduce heat transfer through the roof resulting in more consistent roof temperatures between eave and field of roof.
- Increase the degree of diligence with respect to underlayment materials at roof areas prone to icing. This may include valleys, eaves, dormers and roof areas near dormers, parapets and the like where shading may occur.

For more information on this subject, please refer to the MCA's Metal Roof Design For Cold Climates manual.

The Engineering data contained herein is for the expressed use of customers and design professionals. Along with this data, it is recommended that the design professional have a copy of the most current version of the North American Specification for the Design of Cold-Formed Steel Structural Members published by the American Iron and Steel Institute to facilitate design. This Specification contains the design criteria for cold-formed steel components. Along with the Specification, the designer should reference the most current building code applicable to the project jobsite in order to determine environmental loads. If further information or guidance regarding cold-formed design practices is desired, please contact the manufacturer.

Descriptions and specifications contained herein were in effect at the time this publication was approved for printing. In a continuing effort to refine and improve products, ABC reserves the right to discontinue products at any time or change specifications and/or designs without incurring obligation. **To ensure you have the latest information available, please inquire or visit our website: [abcmetal.com](http://abcmetal.com).** Application details are for illustration purposes only and may not be appropriate for all environmental conditions, building designs or panel profiles. Projects should be designed to conform to applicable building codes, regulations and accepted industry practices. If there is a conflict between this manual and project erection drawings, the erection drawings will take precedence.

# TABLE OF CONTENTS

## PRODUCT INFORMATION

Design Information .....	S-4
Application, Storage and Handling Information .....	S-5 – 6
16" Wide Square Foot Chart .....	S-7
Freight and Packaging Costs .....	S-8
Load Tables .....	S-9
Slimline® UL® Technical Data .....	S-10
Product Checklist .....	S-11 - S-18
How To Order Special Trim .....	S-19

## DETAILS

Panel Engagement .....	S-20
------------------------	------

### EXPOSED FASTENER DETAILS

Ridge .....	S-21
Hip .....	S-22
Peak Trim .....	S-23
Eave .....	S-24
Rake .....	S-26
Valley .....	S-27
Side Wall .....	S-28
End Wall .....	S-29

### CONCEALED FASTENER DETAILS

Ridge/Hip .....	S-30
Hip .....	S-31
Peak Trim .....	S-32
Field Hemming Panel End .....	S-33
Valley with Offset Cleat .....	S-34
Eave with Offset Cleat .....	S-35
Eave Trim with Drip Edge .....	S-36
Rake .....	S-37
Side Wall .....	S-38
End Wall .....	S-39
Roof Transition .....	S-40

### OTHER DETAILS

Slope Change - Fixed Eave .....	S-41
Slope Change - Floating Eave .....	S-42
Profile Vent .....	S-43

# PRODUCT INFORMATION

## DESIGN INFORMATION

### PLANNING

Consult a qualified engineer or architect to be sure that your particular application of this product conforms to applicable building codes, regulations, environmental conditions and accepted industry practices. All suggested applications for Slimline® assume a qualified engineer or architect has been consulted prior to the application of the product. Please note that the details shown may not be appropriate for all environmental conditions and building applications. Prior to ordering panels, all dimensions should be confirmed by field measurements by the customer or installer.

### APPLICATIONS

Slimline® is a non-structural, water shedding concealed fastener panel system that can be applied on a variety of projects. They include roofing, siding, mansard, or fascia systems. Slimline® contemporary design, with economical interlocking ribs and fastening flanges make it ideally suitable for new construction or retrofit markets on both light commercial and residential projects. For panels longer than 36' please inquire. Panels may not be endlapped.

### ROOF SUBSTRATE

For roofing applications, apply Slimline® over a properly aligned, smooth continuous structural substrate such as 5/8" or thicker plywood surface with a suitable moisture barrier.

### WATER/VAPOR CONTROL (MOISTURE BARRIER UNDERLAYMENT)

When warm moist air contacts a cold surface such as the underside of a metal roof panel, the water vapor contained in it condenses. The continuous presence of moisture is detrimental to many things, including metal. The use of suitable moisture/vapor barrier and insulations protect the metal and your investment. The minimum acceptable barrier would be 30# builders felt. Other breathable barriers such as "Shingle Mate®" or "StormGuard® HT" from GAF Materials Corporation provide exceptional long term protections when applied as directed by the manufacturer. Whatever barrier you decide to use must be applied in a smooth continuous manner, free from holes or rips. Fasteners used to attach the barrier must be covered to protect the underside of the panels. Fasteners must be flush with the surface of the barrier or they will cause unwanted distortion of the panel surface. It is further recommended that peak and eave or gable vents be installed to provide adequate air flow in trapped air spaces such as attics. Consult a qualified design professional for venting requirements.

### OIL CANNING

Flat surface areas in metal panels are subject to visible stress. This "oil canning" (wave) is evident to some degree in all flat metal surfaces. Every effort is taken to minimize this condition during the forming process. Oil canning does not affect the structural integrity of the panel and is not a cause for rejection. For information on this subject, please refer to MCA's oil canning technical bulletin.

### FASTENERS

Slimline® panels are best secured to a solid wood substrate by using a 10 x 1" Type A pancake head fastener. Fastener spacing is dependent upon design considerations. A qualified engineer must be consulted to insure that all design codes and other pertinent criteria are met. Refer to load tables on pages S-9. Refer to page S12 for additional fastener information. Do not overdrive fasteners. This can cause panel distortion.

## Product Selection Chart

Gauge	Galvalume Plus	Signature 200
26-Gauge	●	■
29-Gauge	●	■

- Available in any quantity
- Minimum order quantities and extended lead times may apply.

# PRODUCT INFORMATION

## APPLICATION, STORAGE AND HANDLING INFORMATION

### SAFETY PRECAUTIONS

Improper unloading and handling of bundles and crates may cause bodily injury or material damage. Use extreme care in the operation of power lifting devices such as cranes and forklifts and follow the safety instructions provided by their manufacturer. Crates, boxes and bundles may be bulky, heavy, or both. The improper or unaided lifting of them may cause bodily injury. The manufacturer is not responsible for bodily injuries or material damage due to improper handling during unloading, storage, or job site placement.

Protective heavy duty gloves should be worn when handling metal panels and trim products. Safety goggles or face shield should be worn while cutting or drilling metal products with power tools. Follow the safety instructions provided by the manufacturer of the power tools.

Use extreme care when walking, sitting, standing, or kneeling on a metal roof to avoid a fall. Galvalume® and galvanized panels have a light coating of oil to protect the panels from moisture prior to erection. They can be extremely slippery, as are painted panels, when they are wet. If necessary, remove the oil coating with a non-abrasive detergent and water mixture followed by a clear water rinse. Insure the panels are dry prior to installation.

### STORAGE AND HANDLING

To preserve and protect the attractive appearance of American Building Components' roofing and siding from damage caused by moisture, corrosive chemicals or improper handling, it is necessary that you take a few simple precautions. When material is received bundled, panels should be inspected for moisture. If there is moisture, the panels should be separated and dried. If shipping damage is found, the carrier should be advised and a notation made on the bill of lading.

On job sites, reasonable care should be taken when handling painted surfaces during installation in order to protect the finish. Although the paint coating is tough and provides impact resistance, dragging panels across the surface of one another will almost certainly mar the finish.

Prolonged storage of sheets in bundles is not recommended. If conditions do not permit immediate erection, extra care must be taken to protect the material from damage caused by moisture.

Store bundled sheets ONLY IN A DRY PLACE. Sheets should be unbundled, stood on end against an interior wall to allow for air circulation. If unable to store sheets in an upright position, strapping bands should be broken and sheets should be blocked off the floor with one end slightly elevated. Stacked sheets should then be completely protected from the elements while maintaining good airflow to prevent condensation. A properly draped canvas tarpaulin, that allows air flow, is an example of a good protective cover. Do not use plastic as it causes sweating or condensation to occur.

### BUILDING DESIGN AND CONSTRUCTION

It is important to protect metal panels from potentially corrosive situations and materials. This will insure the good performance and long life of the metal. If installing metal panels over green lumber, damp lumber, or treated lumber (CCA or ACQ), a barrier must be installed to separate the wood from the metal. A barrier may be formed with plastic or other suitable material. Avoid contact with, or water runoff from, dissimilar metals such as copper, lead or graphite. Dissimilar metals under the roof panels may be separated with asphalt, builders felt, caulking compounds or gasket material.

Metal panels must further be protected from contact with strong chemicals such as fertilizers, lime acids, animal waste and soil. All of these have the potential to initiate corrosion in metal panels. Metal panels should not be in permanent contact with soil.

Temperature variations, (dew point) between the outside air and the interior building air mass can cause condensation to occur on the inside of the building on the panel's surfaces. Proper venting and air flow consideration and the use of a vapor barrier such as vinyl backed insulation can eliminate this problem. If left unattended, condensation can cause the premature degradation of the metal and void any applicable warranties. For information on this subject, please refer to MCA's white paper on controlling condensation in steep slope metal roofing systems.

**The substructure, on which the panels are to be installed, must be "on plane" (1/4" tolerance) from eave to ridge. Maximum recommended panel length is 36'; minimum panel length is 3'.**

### VENTILATION

Sufficient air movement should be provided by means of a ridge or rotary vent, power operated fans, or other openings to minimize condensation. Contact the equipment manufacturer for specific information or a qualified mechanical engineer.

# PRODUCT INFORMATION

## APPLICATION, STORAGE AND HANDLING INFORMATION (cont'd)

### ROOFING INSTALLATION

Check substructure for proper alignment and uniformity to avoid panel distortion. ABC recommends the use of  $\frac{5}{8}$ " plywood for the substructure. Minimum  $\frac{5}{8}$ " plywood substructure is MANDATORY for UL 90 Uplift Rating.

THE MINIMUM roof slope recommended is 3 inches of rise per foot. This ensures that sufficient slope is present for adequate drainage. The panels must be installed over a completely water-proofed substructure.

It is important to remember that in the installation of roof sheets, the sidelaps should face away from the direction of the prevailing wind. The first sheet should be installed square with the eave and at the down-wind end of the roof, farthest from the direction of the wind.

For proper fastener application, refer to our published guide.

Remember to sweep the roof clean of any metal filings created from fastener placement or cutting of panels to prevent rust marks on the surface of the painted panels.

Installing Slimline® panels over an uneven substrate will cause distortion of the panel. It is the responsibility of the installer to insure a suitable substrate prior to panel application. Distortion in the panel caused by an uneven substrate, ripples or laps in the vapor barrier, debris, etc., are not defects in the material, and are not the responsibility of ABC. Slimline® panels cannot be endlapped.

### CLOSURES AND SEALANTS

To thoroughly protect the contents of any structure from moisture, regardless of building size or roof slope, closure strips should be used at the roof ridge, hip and eave.

For maximum protection, all caulking used should be urethane. **Silicone caulks are not recommended for panels or trims.**

### CUTTING METAL PANELS

ABC recommends the use of power shears or nibblers that can follow the contour of the panel's profile. While not recommended, if a power saw is to be used, you must use a blade designed to cut the metal at a low temperature to prevent melting of the Galvalume® coating, such as the Slasher® from Dynamic Fastener. You should protect the panel during the cutting process to prevent marring the panel surface. Panels should be thoroughly brushed after cutting to remove any particles of metal and caution should be taken that filings from cutting don't settle on other panels. Follow the safety instructions provided by the manufacturer when using any tools.

### PANEL SELECTION

If you chose a bare Galvalume® (Galvalume Plus®), for your application you should be aware that this product is recommended for applications where aesthetic appearance is not your prime concern. Unpainted products may not weather uniformly and while they may be shiny and bright when new, they will fade or "patina" with age. Acid rain and other corrosive atmospheres, as well as the accumulation of airborne debris and dirt will affect this aging process and the products' appearance.

If aesthetic appearance is one of your concerns, ABC recommends you select one of our many color coated panel selections. Copies of ABC's color coated panel warranty are available at your point of purchase, or from the ABC office located nearest to you.

Failure to comply with these precautions relieves the manufacturer of responsibility for any resultant damage to, or deterioration of the product and voids any applicable warranties. Contact your local ABC facility for copies of our Limited Color Coated and Galvalume® warranties. Except as outlined in our published limited warranties, ABC makes no warranty, express or implied, limited or otherwise, as to the merchantability or fitness for any particular purpose, with respect to the product sold.

# PRODUCT INFORMATION

## SQUARE FOOT CHART

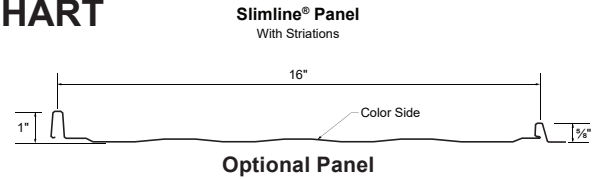
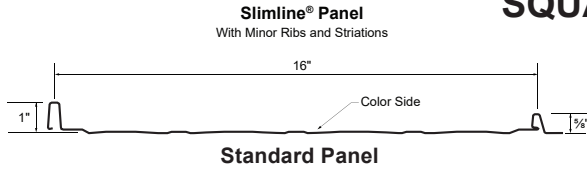

Number of Square Feet Per Panel

	0"	1"	2"	3"	4"	5"	6"	7"	8"	9"	10"	11"
1 FT.	1.33	1.44	1.56	1.67	1.78	1.89	2.00	2.11	2.22	2.33	2.44	2.56
2 FT.	2.67	2.78	2.89	3.00	3.11	3.22	3.33	3.44	3.56	3.67	3.78	3.89
3 FT.	4.00	4.11	4.22	4.33	4.44	4.58	4.67	4.78	4.89	5.00	5.11	5.22
4 FT.	5.33	5.44	5.56	5.67	5.78	5.89	6.00	6.11	6.22	6.33	6.44	6.56
5 FT.	6.67	6.78	6.89	7.00	7.11	7.22	7.33	7.44	7.56	7.67	7.78	7.89
6 FT.	8.00	8.11	8.22	8.33	8.44	8.56	8.67	8.78	8.89	9.00	9.11	9.22
7 FT.	9.33	9.44	9.56	9.67	9.78	9.89	10.00	10.11	10.22	10.33	10.44	10.56
8 FT.	10.67	10.78	10.89	11.00	11.11	11.22	11.33	11.44	11.56	11.67	11.78	11.89
9 FT.	12.00	12.11	12.22	12.33	12.44	12.56	12.67	12.78	12.89	13.00	13.11	13.22
10 FT.	13.33	13.44	13.56	13.67	13.78	13.89	14.00	14.11	14.22	14.33	14.44	14.56
11 FT.	14.67	14.78	14.89	15.00	15.11	15.22	15.33	15.44	15.56	15.67	15.78	15.89
12 FT.	16.00	16.11	16.22	16.33	16.44	16.56	16.67	16.78	16.89	17.00	17.11	17.22
13 FT.	17.33	17.44	17.56	17.67	17.78	17.89	18.00	18.11	18.22	18.33	18.44	18.56
14 FT.	18.67	18.78	18.89	19.00	19.11	19.22	19.33	19.44	19.56	19.67	19.78	19.89
15 FT.	20.00	20.11	20.22	20.33	20.44	20.56	20.67	20.78	20.89	21.00	21.11	21.22
16 FT.	21.33	21.44	21.56	21.67	21.78	21.89	22.00	22.11	22.22	22.33	22.44	22.56
17 FT.	22.67	22.78	22.89	23.00	23.11	23.22	23.33	23.44	23.56	23.67	23.78	23.89
18 FT.	24.00	24.11	24.22	24.33	24.44	24.56	24.67	24.78	24.89	25.00	25.11	25.22
19 FT.	25.33	25.44	25.56	25.67	25.78	25.89	26.00	26.11	26.22	26.33	26.44	26.56
20 FT.	26.67	26.78	26.89	27.00	27.11	27.22	27.33	27.44	27.56	27.67	27.78	27.89
21 FT.	28.00	28.11	28.22	28.33	28.44	28.56	28.67	28.78	28.89	29.00	29.11	29.22
22 FT.	29.33	29.44	29.56	29.67	29.78	29.89	30.00	30.11	30.22	30.33	30.44	30.56
23 FT.	30.67	30.78	30.89	31.00	31.11	31.22	31.33	31.44	31.56	31.67	31.78	31.89
24 FT.	32.00	32.11	32.22	32.33	32.44	32.56	32.67	32.78	32.89	33.00	33.11	33.22
25 FT.	33.33	33.44	33.56	33.67	33.78	33.89	34.00	34.11	34.22	34.33	34.44	34.56
26 FT.	34.67	34.78	34.89	35.00	35.11	35.22	35.33	35.44	35.56	35.67	35.78	35.89
27 FT.	36.00	36.11	36.22	36.33	36.44	36.56	36.67	36.78	36.89	37.00	37.11	37.22
28 FT.	37.33	37.44	37.56	37.67	37.78	37.89	38.00	38.11	38.22	38.33	38.44	38.56
29 FT.	38.67	38.78	38.89	39.00	39.11	39.22	39.33	39.44	39.56	39.67	39.78	39.89
30 FT.	40.00	40.11	40.22	40.33	40.44	40.56	40.67	40.78	40.89	41.00	41.11	41.22
31 FT.	41.33	41.44	41.55	41.67	41.78	41.89	42.00	42.11	42.22	42.33	42.44	42.56
32 FT.	42.67	42.78	42.89	43.00	43.11	43.22	43.33	43.44	43.56	43.67	43.78	43.89
33 FT.	44.00	44.11	44.22	44.33	44.44	44.56	44.67	44.78	44.89	45.00	45.11	45.22
34 FT.	45.33	45.44	45.56	45.67	45.78	45.89	46.00	46.11	46.22	46.33	46.44	46.56
35 FT.	46.67	46.78	46.89	47.00	47.11	47.22	47.33	47.44	47.56	47.67	47.78	47.89
36 FT.	48.00	48.11	48.22	48.33	48.44	48.56	48.67	48.78	48.89	49.00	49.11	49.22
37 FT.	49.33	49.44	49.56	49.67	49.78	49.89	50.00	50.11	50.22	50.33	50.44	50.56
38 FT.	50.67	50.78	50.89	51.00	51.11	51.22	51.33	51.44	51.56	51.67	51.78	51.89
39 FT.	52.00	52.11	52.22	52.33	52.44	52.56	52.67	52.78	52.89	53.00	53.11	53.22
40 FT.	53.33	53.44	53.56	53.67	53.78	53.89	54.00	54.11	54.22	54.33	54.44	54.56

# PRODUCT INFORMATION

## FREIGHT AND PACKAGING COST

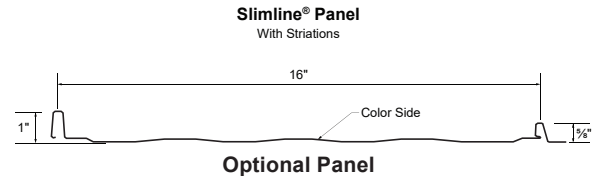
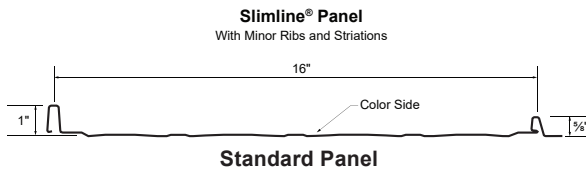

**PANEL PRICING:**

1. All pricing is based on net coverage.
2. For panel lengths under 4'-0" add \$1.05 per sheet.
3. Panels are custom cut-to-the-inch.
4. Panels must be specified as: "Striated" or "Striated with Minor Ribs".

\*Please inquire for other panel types.

**PACKAGING COST:**

Standard Packaging: Strippable film on panel ribs, wood saddles and trusses as required \$6.00 per square - \$60.00 minimum charge.

**DELIVERY:**

1. 29 gauge premium colors ..... Approximately 15 working days.
2. Other gauges, colors, and metals ..... Please inquire.

**NOTES:**

1. For panels—lengths longer than 36'-0" ..... Please inquire. (generally two lifts must be used for panels over 30'0")
2. Minimum panel length of 3'.
3. Recommended roofing applications are over a solid substrate (5/8" plywood with a suitable moisture/vapor barrier).
4. Minimum roof pitch for a roofing application is 3" of rise per foot (3:12).
5. Oil canning is not a cause for rejection.

FREIGHT: All prices are F.O.B. shipping point.

FREIGHT CHARGES: 8% freight and fuel charge. If outside 250-mile radius of shipping plant, orders will have a minimum of \$375 or specified percentage whichever is greater.

1. Stop over charge (for unloading delay in excess of 1½ hrs. Charged in ½ hr. increments)...\$90.00 per hour.
2. Job Site Delivery: \$75.00 Minimum.
3. Refer to price sheets for freight notes.

ABC is pleased to provide job site delivery to our customers. Customers requesting this service must have mechanized means to off-load the material (i.e. crane, forklift, gin pole). The job site location must be accessible to a vehicle 65' long and weighing up to 80,000 pounds. ABC reserves the right to refuse delivery at job sites where unsafe or impassable terrain or road conditions are present.

# PRODUCT INFORMATION

## 29 GAUGE LOAD TABLES

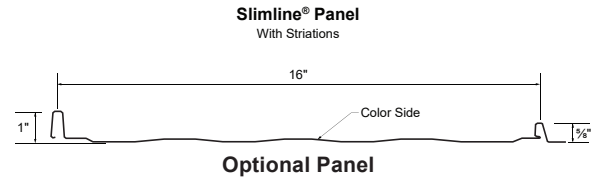
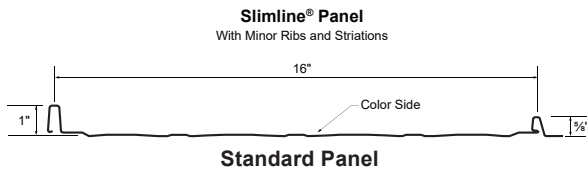

### Negative Design Loads

Span	ASTM E-1592	Design Load
FT	PSF	PSF
1.00	62.40	31.20
1.50	54.60	27.30
2.00	46.80	23.40
2.50	44.20	22.10
3.00	41.60	20.80

**NOTES:**

1. The above loads were derived from uplift tests done in accordance with ASTM E-1592
2. All values are interpolated and/or extrapolated from tests performed at spans of 1'-0", 2'-0" and 3'-0".
3. Design Load contains a 2.00 factor of safety.
4. These values do not consider fastener pullout or pullover. Attachment must be designed separately.
5. The use of any accessories, including fasteners, other than those provided by the manufacturer may damage panels, void all warranties and will void all engineering data.
6. This material is subject to change without notice. Please contact ABC for most current data.

Descriptions and specifications contained herein were in effect at the time this publication was approved for printing. ABC reserves the right to discontinue products at any time or change specifications and/or designs without notice and without incurring obligation. Application details are for illustration purposes only and may not be appropriate for all environmental conditions, building designs, or panel profiles. Projects should be engineered to conform to applicable building codes, regulations and accepted industry practices.

# PRODUCT INFORMATION

## UL® TECHNICAL DATA



### Construction #529 Slimline® over Plywood

1. Metal Panels (29 gauge or heavier)—16" wide, continuous over two or more spans.
2. Substructure (Plywood)—plywood decking to be a nominal 5/8" thick.
3. Fasteners—No. 10 X 1" long No. 2 Phillips pancake head wood screw spaced 1'-0" O.C.
4. Joists—joists spaced 2' O.C. may be one of the following:
  - A. Nom. 2" x 6" wood joists No. 2 or better.
  - B. Nom. 2" x 4" wood when used on a top cord of a wood truss, No. 2 or better.
  - C. Light gauge structural steel framing with the member against the plywood to be a minimum No. 22 msg coated steel.

## FIRE RESISTANCE RATING

External Fire Exposure: Class A

Mechanically attached metal roof panels—type Slimline® 16" (29 msg). Secured by No. 10 X 1" No. 2 Phillips pancake head wood screw.

For use in: "Design Nos. P224, P225, P227, P230, P233, P237, P265, P268, P508, P510, P512, P701, P711, P715, P717, P720, P722, P724, P726, P731, P734, P736, P801, P803, P814, P815, P819, P821 and P823".

See **UL FIRE RESISTANCE DIRECTORY** for details of illustrations and fire resistance hourly ratings.

## IMPACT RESISTANCE

UL Classification as to Impact Resistance: Class 4

### CAUTION

For UL 90 Rated Roofs, the above requirements must be followed. See UL Roofing Materials and Systems Directory for additional requirements. If you have any questions, call ABC before proceeding.

# PRODUCT INFORMATION

## PRODUCT CHECKLIST

**Slimline® Series**

MINOR RIBS WITH STRIATIONS

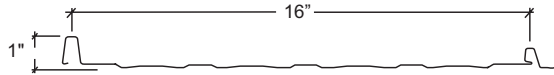

**16" Outside Closure**

- Outside Closure
- Contains Adhesive



HW-492

**Panel Hemming Tool**

- Width: 19"

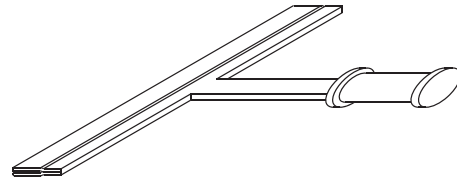

HW-602

**Tape Sealer - Tri-Bead Tape**

- Width: 7/8"
- Thickness: 3/16"
- Length: 25'-0"
- 8 Per Carton



HW-504

NOTES: Sold by carton only

**Tape Sealer - Triple Bead Tape**

- Width: 2 1/2"
- Thickness: 3/16"
- Length: 20'-0"
- 6 Per Carton



HW-502

NOTES: Sold by carton only

**Tube Sealant**

- Urethane Sealant
- 11 oz. Tubes
- 30 Per Carton

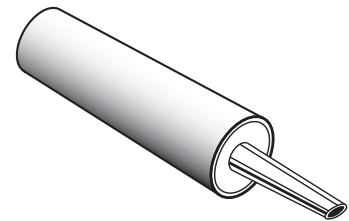

HW-540 - White



HW-541 - Gray

HW-542 - Bronze

NOTES: 25' per tube at 1/4" bead

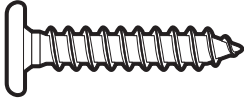
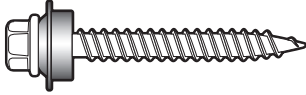
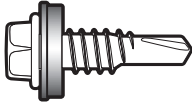
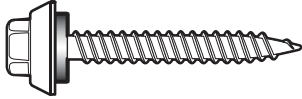

# PRODUCT INFORMATION

## PRODUCT CHECKLIST

<p><b>Pancake Head</b></p> <ul style="list-style-type: none"> <li>• Panel to Substructure at Fastener Flange</li> <li>• #2 Phillips</li> <li>• 250 Per Bag</li> </ul>  <p>#13 - 10 x 1" <input type="checkbox"/></p>	<p><b>Wood Fastener</b></p> <ul style="list-style-type: none"> <li>• Panel to wood</li> <li>• Head size ¼"</li> <li>• 250 Per Bag</li> </ul>  <p>8A - 10 x 1" <input type="checkbox"/>              8 - 10 x 1½" <input type="checkbox"/>              8B - 10 x 2" <input type="checkbox"/>              8C - 10 x 2½" <input type="checkbox"/></p>
<p><b>Lap-Tek</b></p> <ul style="list-style-type: none"> <li>• Trim Fastener</li> <li>• Head Size ⅝"</li> <li>• 250 Per Bag</li> </ul>  <p>4A - 14 x ⅞" <input type="checkbox"/></p>	<p><b>Long Life Wood Fastener</b></p> <ul style="list-style-type: none"> <li>• Panel to wood</li> <li>• Head size ⅝"</li> <li>• 250 Per Bag</li> </ul>  <p>*Special order              NOTES: Other Sizes Available.</p> <p>#9A - 10 x 1" <input type="checkbox"/>              #9 - 10 x 1½" <input type="checkbox"/></p>
<p><b>Pop Rivet</b></p> <ul style="list-style-type: none"> <li>• Stainless Steel Trim</li> <li>• 250 Per Bag</li> </ul>  <p>#14 - ⅛ x ⅜" <input type="checkbox"/></p>	<p><b>Type A</b></p> <ul style="list-style-type: none"> <li>• Panel to Plywood at Exposed Locations</li> <li>• Head Size ⅝"</li> <li>• 250 Per Bag</li> </ul>  <p>#18 - 14 x 1" <input type="checkbox"/>              #18B - 14 x 1½" <input type="checkbox"/>              #18C - 14 x 2" <input type="checkbox"/></p>

# PRODUCT INFORMATION

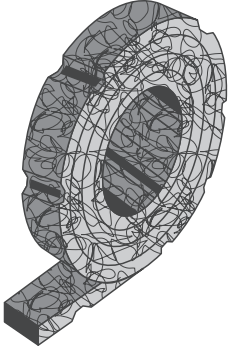
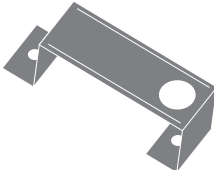
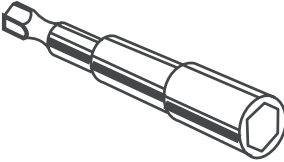
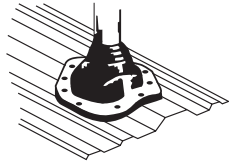
## PRODUCT CHECKLIST

<p><b>Profile Vent</b></p> <ul style="list-style-type: none"> <li>• 100' Roll</li> </ul> <div style="text-align: center;">  </div> <p style="text-align: right;"><b>HW-116SL16</b> <input type="checkbox"/></p>	<p><b>Profile Vent Anchor Clip</b></p> <ul style="list-style-type: none"> <li>• Two per panel</li> <li>• Sold in quantities of 25 pieces</li> </ul> <div style="text-align: center;">  </div> <p style="text-align: right;"><b>HW-2076</b> <input type="checkbox"/></p>																																								
<p><b>One Piece Magnetic Socket</b></p> <div style="text-align: center;">  </div> <p style="text-align: right;"><b>HW-606</b> - 1/4" <input type="checkbox"/> <b>HW-605</b> - 5/16" <input type="checkbox"/></p>	<p><b>Rubber Roof Jack</b></p> <div style="text-align: center;">  </div>																																								
<p><b>Touch Up Paint - Brush Top Can</b></p> <ul style="list-style-type: none"> <li>• 2 oz. bottle with brushes</li> <li>• Standard Colors</li> <li>• Recommended for minor scratch cover only</li> </ul> <div style="text-align: center;">  </div> <p style="text-align: right;"><b>HW-304</b> <input type="checkbox"/></p>	<table border="1" style="width: 100%; border-collapse: collapse;"> <thead> <tr style="background-color: #cccccc;"> <th>PIPE SIZE</th> <th>PART NUMBER</th> <th>TEMP. RANGE</th> <th>BASE DIM</th> </tr> </thead> <tbody> <tr> <td>1/4" - 2"</td> <td>HW-1000</td> <td>-65° - +212°</td> <td>4 1/2"</td> </tr> <tr> <td>1/4" - 5"</td> <td>HW-1001</td> <td>-65° - +212°</td> <td>8"</td> </tr> <tr> <td>4" - 7"</td> <td>HW-1002</td> <td>-65° - +212°</td> <td>11"</td> </tr> <tr> <td>6" - 11"</td> <td>HW-1003</td> <td>-65° - +212°</td> <td>14"</td> </tr> <tr> <td>7" - 13"</td> <td>HW-1004</td> <td>-65° - +212°</td> <td>17"</td> </tr> </tbody> </table> <p><b>Retrofit Rubber Roof Jack</b></p> <div style="text-align: center;">  </div> <table border="1" style="width: 100%; border-collapse: collapse;"> <thead> <tr style="background-color: #cccccc;"> <th>PIPE SIZE</th> <th>PART NUMBER</th> <th>TEMP. RANGE</th> <th>BASE DIM</th> </tr> </thead> <tbody> <tr> <td>1/2" - 4"</td> <td>HW-1005</td> <td>-65° - +212°</td> <td>8 1/16"</td> </tr> <tr> <td>4" - 9 1/4"</td> <td>HW-1006</td> <td>-65° - +212°</td> <td>14 1/4"</td> </tr> <tr> <td>9 1/4" - 16 1/4"</td> <td>HW-1007</td> <td>-65° - +212°</td> <td>21 1/2"</td> </tr> </tbody> </table> <p>High Temperature per special order. Please inquire.</p>	PIPE SIZE	PART NUMBER	TEMP. RANGE	BASE DIM	1/4" - 2"	HW-1000	-65° - +212°	4 1/2"	1/4" - 5"	HW-1001	-65° - +212°	8"	4" - 7"	HW-1002	-65° - +212°	11"	6" - 11"	HW-1003	-65° - +212°	14"	7" - 13"	HW-1004	-65° - +212°	17"	PIPE SIZE	PART NUMBER	TEMP. RANGE	BASE DIM	1/2" - 4"	HW-1005	-65° - +212°	8 1/16"	4" - 9 1/4"	HW-1006	-65° - +212°	14 1/4"	9 1/4" - 16 1/4"	HW-1007	-65° - +212°	21 1/2"
PIPE SIZE	PART NUMBER	TEMP. RANGE	BASE DIM																																						
1/4" - 2"	HW-1000	-65° - +212°	4 1/2"																																						
1/4" - 5"	HW-1001	-65° - +212°	8"																																						
4" - 7"	HW-1002	-65° - +212°	11"																																						
6" - 11"	HW-1003	-65° - +212°	14"																																						
7" - 13"	HW-1004	-65° - +212°	17"																																						
PIPE SIZE	PART NUMBER	TEMP. RANGE	BASE DIM																																						
1/2" - 4"	HW-1005	-65° - +212°	8 1/16"																																						
4" - 9 1/4"	HW-1006	-65° - +212°	14 1/4"																																						
9 1/4" - 16 1/4"	HW-1007	-65° - +212°	21 1/2"																																						

# PRODUCT INFORMATION

## EXPOSED FASTENER TRIM

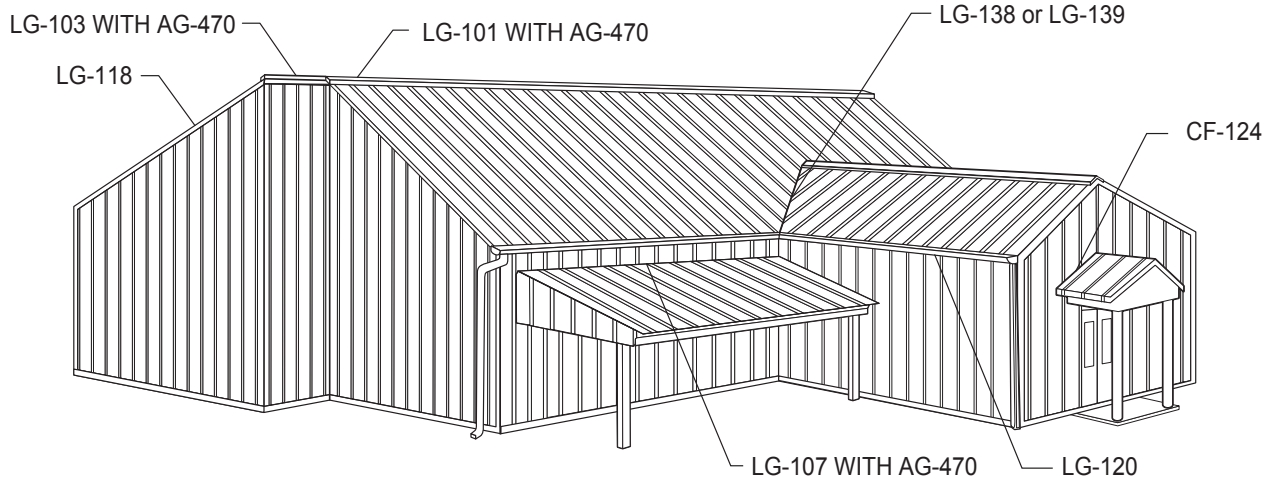

**LG-101**  
PLAIN RIDGE CAP

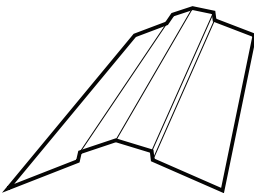

**LG-103**  
DENVER PEAK

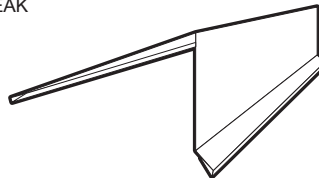

**LG-107**  
DENVER ENDWALL FLASH

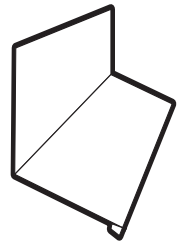

**LG-118**  
DENVER GABLE

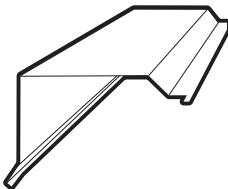

**LG-120**  
DENVER EAVE

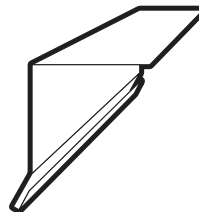

**CF-124**  
SIDEWALL FLASHING

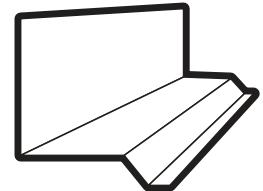

**CF-115**  
RAKE TRIM

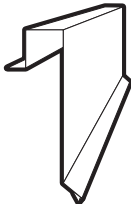

**LG-138**  
"W" FORMED VALLEY  
**LG-139**

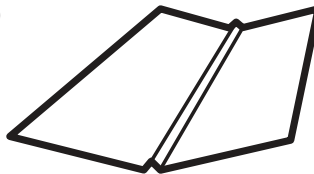

**AG-470**  
ZEE CLOSURE

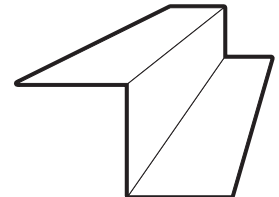



# PRODUCT INFORMATION

## CONCEALED FASTENER TRIM

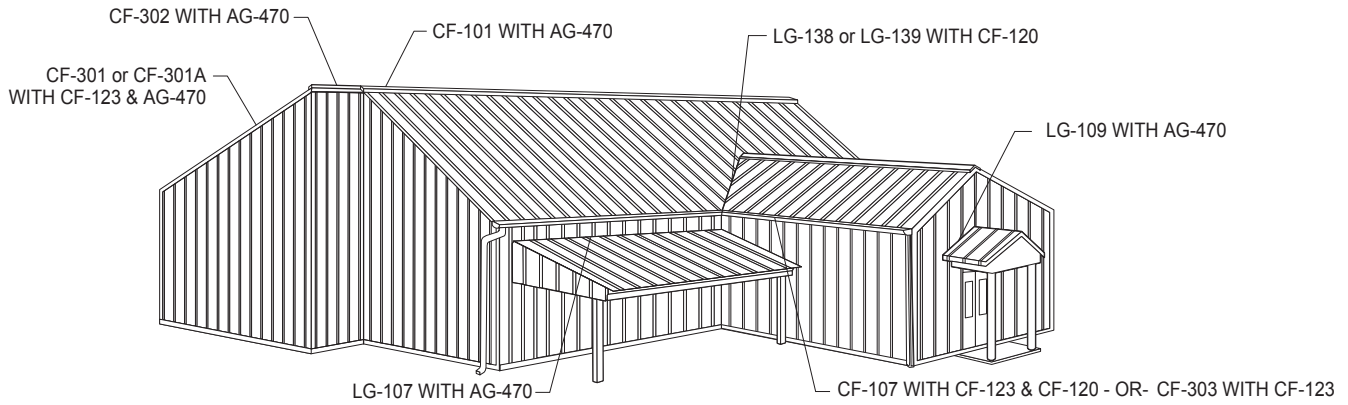

**CF-302**  
CONCEALED PEAK TRIM

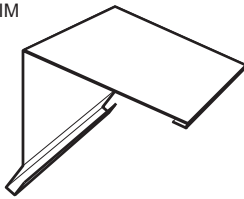

**CF-101**  
RIDGE/HIP

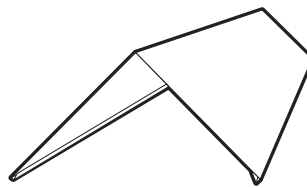

**CF-120**  
OFFSET CLEAT

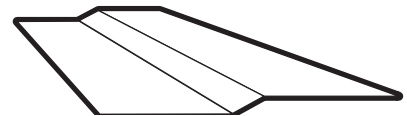

**LG-109**  
DENVER SIDEWALL FLASHING

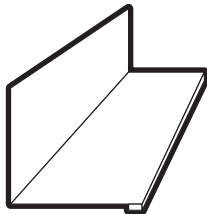

**CF-123**  
CONTINUOUS CLEAT

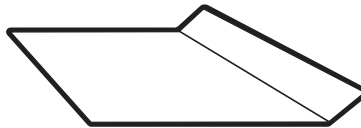

**CF-301**  
**CF-301A**  
CONCEALED RAKE

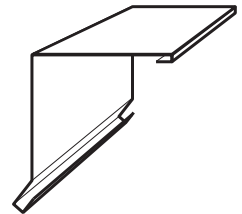

**CF-107**  
CONCEALED EAVE TRIM

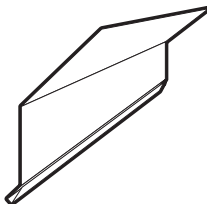

**LG-138**  
**LG-139**  
"W" FORMED VALLEY

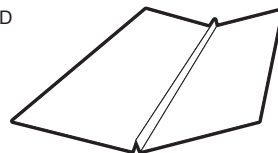

**AG-470**  
ZEE CLOSURE

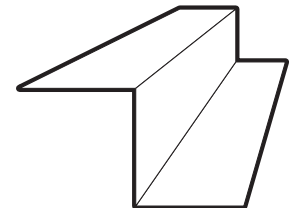

**CF-303**  
EAVE TRIM WITH DRIP EDGE

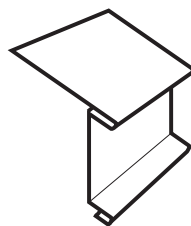

**LG-107**  
DENVER ENDWALL FLASHING

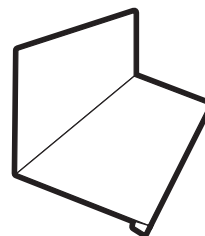

# PRODUCT INFORMATION

## CONCEALED FASTENER TRIM PRODUCT CHECKLIST

### Ridge/Hip

4:12 PITCH STANDARD UNLESS SPECIFIED OTHERWISE

- Length: 10' - 6"

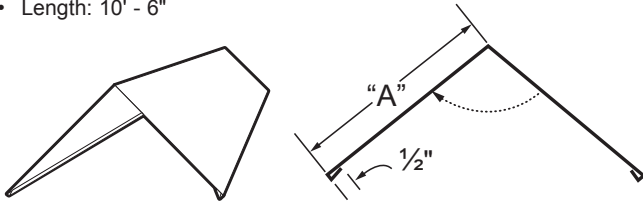

- CF-101** Dim A = 6" Girth = 13"
- CF-101A** Dim A = 7" Girth = 15"
- CF-101B** Dim A = 8" Girth = 17"

### Concealed Peak Trim

4:12 PITCH STANDARD UNLESS SPECIFIED OTHERWISE

- Length: 10' - 6"
- Girth: 11 3/8"
- Closed hem on request

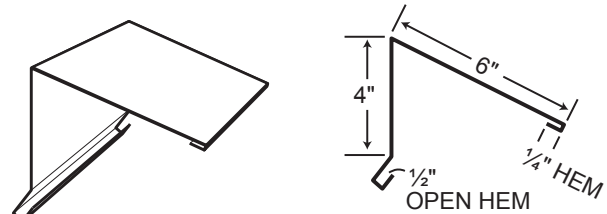

**CF-302**

### Concealed Rake

- Length: 10' - 6"
- Use with AG-470 and CF-123

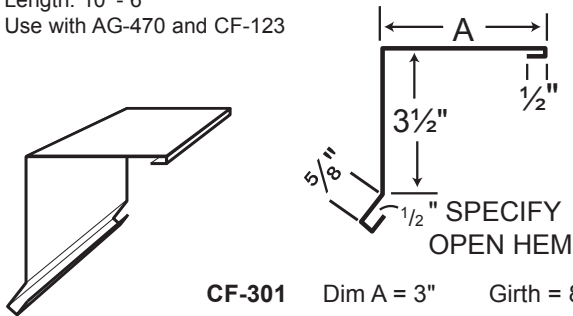

- CF-301** Dim A = 3" Girth = 8 1/8"
- CF-301A** Dim A = 6" Girth = 11 1/8"

### Concealed Eave Trim

4:12 PITCH STANDARD UNLESS SPECIFIED OTHERWISE

- Length: 10' - 6"
- Girth: 7"
- Use with CF-120 and CF-123

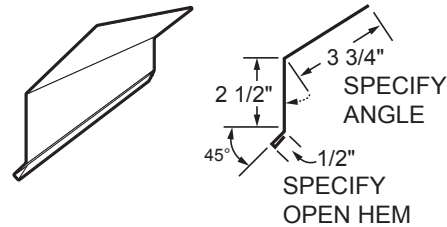

**CF-107**

### Denver Sidewall Flashing

- Length: 10' - 6"
- Girth: 8 1/4"
- Use with AG-470

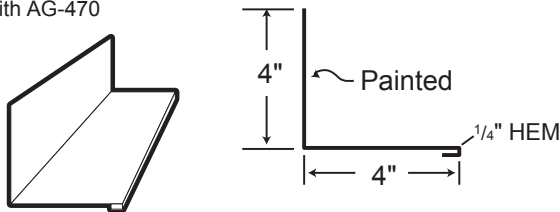

**LG-109**

### Eave Trim with Drip Edge

4:12 PITCH STANDARD UNLESS SPECIFIED OTHERWISE

- Length: 10' - 6"
- Girth: 9 5/8"
- Use with CF-123
- Max bend 6:12 pitch

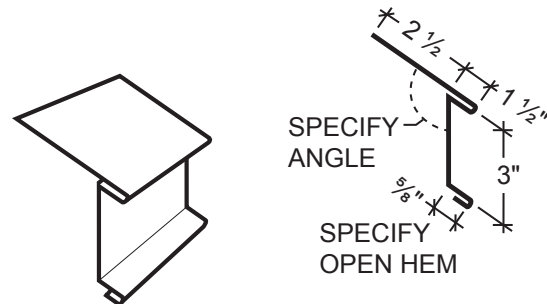

**CF-303**

### Denver Endwall Flash

4:12 PITCH STANDARD UNLESS SPECIFIED OTHERWISE

- Length: 10' - 6"
- Girth: 9 3/4"
- Use with AG-470

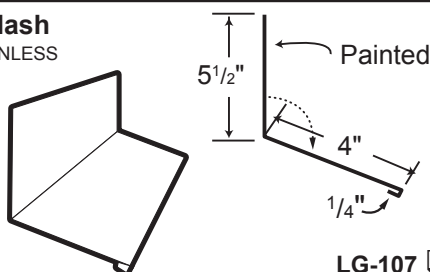

**LG-107**

# PRODUCT INFORMATION

## CONCEALED FASTENER TRIM PRODUCT CHECKLIST

### "W" Formed Valley

- Length: 10' - 6"
- Use with CF-120

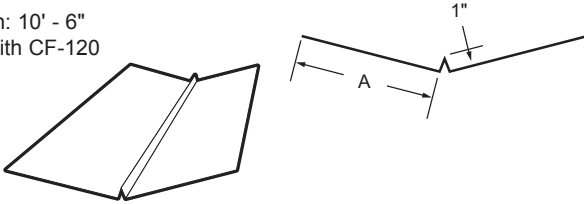

4:12 PITCH STANDARD UNLESS SPECIFIED OTHERWISE

**LG-138** Dim A = 9" Girth = 20"

**LG-139** Dim A = 14" Girth = 30"

### Offset Cleat

- Length: 10' - 6"
- Girth: 3 1/2"

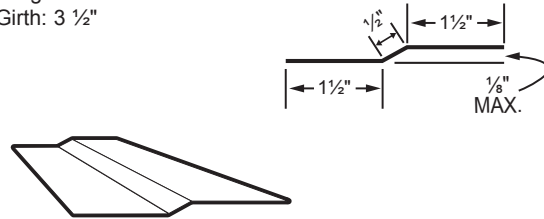

**CF-120**

NOTE: Concealed trim made out of 29 gauge Galvalume Plus®.

### Zee Closure

- Length: 10' - 6"
- Girth: 3"
- Field cut as needed
- Used as outside closure

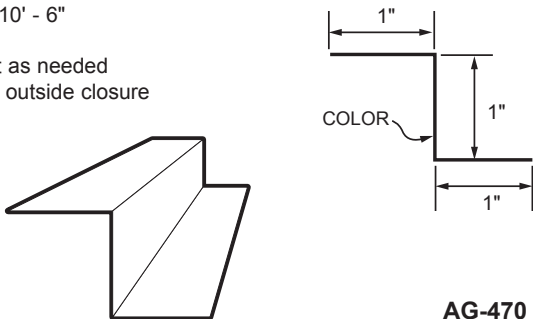

**AG-470**

### Continuous Cleat

- Length: 10' - 6"
- Girth: 3"

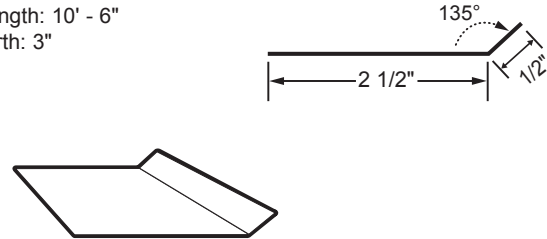

**CF-123**

### Counter Flash

- Length: 10' - 6"
- Girth: 5 1/2"

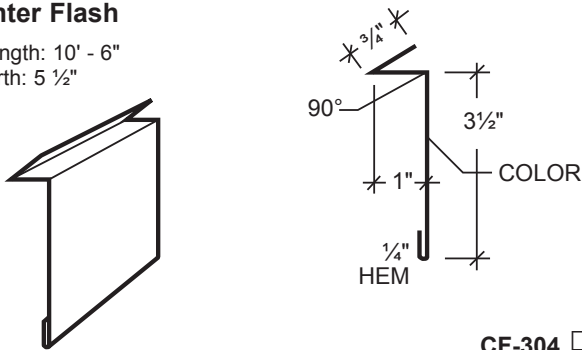

**CF-304**

### Rib Cover

- Length: 0' - 8"

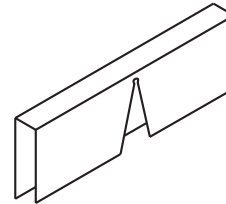

**CF-119**

### Flat Sheet

- 40 7/8" x 126" Galvanized and Color
- 40 7/8" x 126" Galvalume Plus®

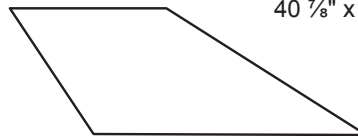

\*Skidding charge of \$42.00 will be added

### Drip Edge

- Length: 10' - 6"
- Girth: 7 3/8"

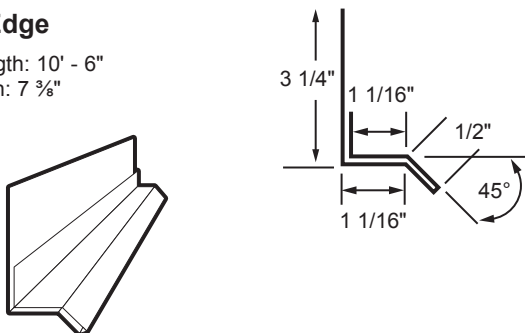

**CF-121**

### Roll Valley

- Length: 50' - 0"
- 29 Gauge
- Width: 20 3/16"

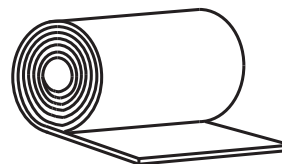

Available in all colors

# PRODUCT INFORMATION

## HOW TO ORDER SPECIAL TRIM DEGREES BASED ON ROOF PITCH

<b>ROOF SLOPE</b>																																																																	
<table border="1" style="width: 100%; border-collapse: collapse;"> <tr> <td style="width: 10%;"></td> <td style="width: 5%;">1:12</td> <td style="width: 5%;">2:12</td> <td style="width: 5%;">3:12</td> <td style="width: 5%;">4:12</td> <td style="width: 5%;">5:12</td> <td style="width: 5%;">6:12</td> <td style="width: 5%;">7:12</td> <td style="width: 5%;">8:12</td> <td style="width: 5%;">9:12</td> <td style="width: 5%;">10:12</td> <td style="width: 5%;">11:12</td> <td style="width: 5%;">12:12</td> </tr> <tr> <td style="padding: 5px;">HIP AND VALLEY</td> <td style="text-align: center;">173°</td> <td style="text-align: center;">166°</td> <td style="text-align: center;">160°</td> <td style="text-align: center;">154°</td> <td style="text-align: center;">148°</td> <td style="text-align: center;">143°</td> <td style="text-align: center;">138°</td> <td style="text-align: center;">133°</td> <td style="text-align: center;">129°</td> <td style="text-align: center;">126°</td> <td style="text-align: center;">123°</td> <td style="text-align: center;">120°</td> </tr> <tr> <td style="padding: 5px;">EAVE AND ENDWALL</td> <td style="text-align: center;">94°</td> <td style="text-align: center;">99°</td> <td style="text-align: center;">104°</td> <td style="text-align: center;">108°</td> <td style="text-align: center;">112°</td> <td style="text-align: center;">116°</td> <td style="text-align: center;">120°</td> <td style="text-align: center;">123°</td> <td style="text-align: center;">126°</td> <td style="text-align: center;">129°</td> <td style="text-align: center;">132°</td> <td style="text-align: center;">135°</td> </tr> <tr> <td style="padding: 5px;">RIDGE</td> <td style="text-align: center;">170°</td> <td style="text-align: center;">161°</td> <td style="text-align: center;">152°</td> <td style="text-align: center;">143°</td> <td style="text-align: center;">135°</td> <td style="text-align: center;">127°</td> <td style="text-align: center;">120°</td> <td style="text-align: center;">113°</td> <td style="text-align: center;">106°</td> <td style="text-align: center;">100°</td> <td style="text-align: center;">95°</td> <td style="text-align: center;">90°</td> </tr> <tr> <td style="padding: 5px;">PEAK</td> <td style="text-align: center;">85°</td> <td style="text-align: center;">81°</td> <td style="text-align: center;">76°</td> <td style="text-align: center;">72°</td> <td style="text-align: center;">67°</td> <td style="text-align: center;">63°</td> <td style="text-align: center;">60°</td> <td style="text-align: center;">56°</td> <td style="text-align: center;">53°</td> <td style="text-align: center;">50°</td> <td style="text-align: center;">47°</td> <td style="text-align: center;">45°</td> </tr> </table>		1:12	2:12	3:12	4:12	5:12	6:12	7:12	8:12	9:12	10:12	11:12	12:12	HIP AND VALLEY	173°	166°	160°	154°	148°	143°	138°	133°	129°	126°	123°	120°	EAVE AND ENDWALL	94°	99°	104°	108°	112°	116°	120°	123°	126°	129°	132°	135°	RIDGE	170°	161°	152°	143°	135°	127°	120°	113°	106°	100°	95°	90°	PEAK	85°	81°	76°	72°	67°	63°	60°	56°	53°	50°	47°	45°
	1:12	2:12	3:12	4:12	5:12	6:12	7:12	8:12	9:12	10:12	11:12	12:12																																																					
HIP AND VALLEY	173°	166°	160°	154°	148°	143°	138°	133°	129°	126°	123°	120°																																																					
EAVE AND ENDWALL	94°	99°	104°	108°	112°	116°	120°	123°	126°	129°	132°	135°																																																					
RIDGE	170°	161°	152°	143°	135°	127°	120°	113°	106°	100°	95°	90°																																																					
PEAK	85°	81°	76°	72°	67°	63°	60°	56°	53°	50°	47°	45°																																																					

**NOTES:**

1. Always indicate the dimension of each segment.
2. Always indicate each angle in degrees
3. Indicate the number of hemmed edges
4. Always indicate the exposed or colored side of each trim piece.
5. Calculate girth, which is the total width of trim piece.

**TRANSITION FLASHING**

	<b>FROM</b>											
	12:12	11:12	10:12	9:12	8:12	7:12	6:12	5:12	4:12	3:12	2:12	1:12
1:12	139°	142°	144°	147°	150°	154°	158°	162°	168°	172°	177°	
2:12	144°	147°	149°	152°	156°	159°	163°	167°	171°	176°		
3:12	149°	151°	154°	157°	160°	163°	167°	171°	175°			
4:12	153°	156°	158°	161°	164°	168°	172°	176°				
5:12	157°	160°	162°	165°	168°	172°	176°					
6:12	161°	164°	166°	169°	172°	176°						
7:12	165°	167°	170°	173°	176°							
8:12	168°	171°	173°	176°								
9:12	172°	174°	177°									
10:12	175°	177°										
11:12	177°											
12:12												

# DETAILS

## PANEL ENGAGEMENT

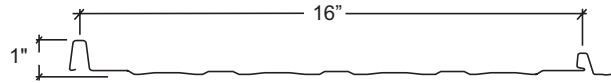

MINOR RIBS WITH STRIATIONS

## PANEL PROFILE

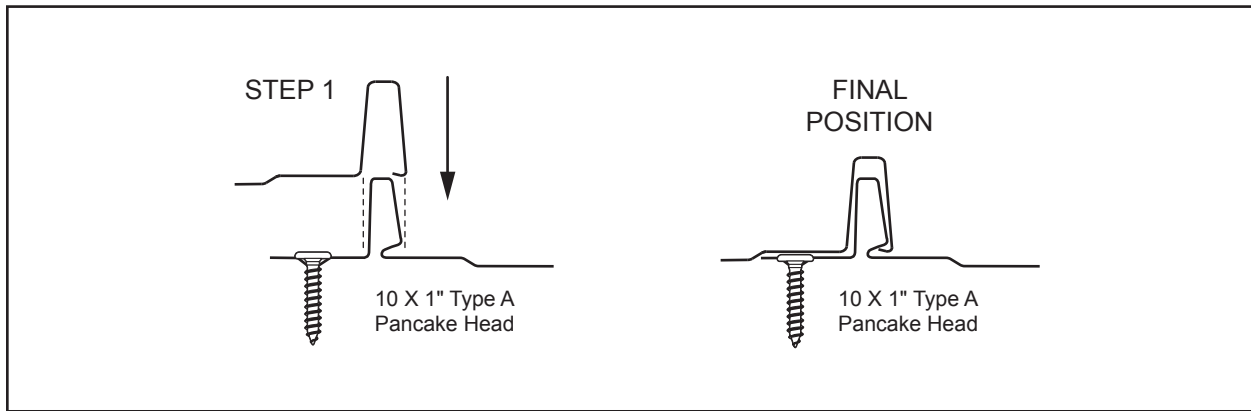

## PANEL SIDELAP ENGAGEMENT

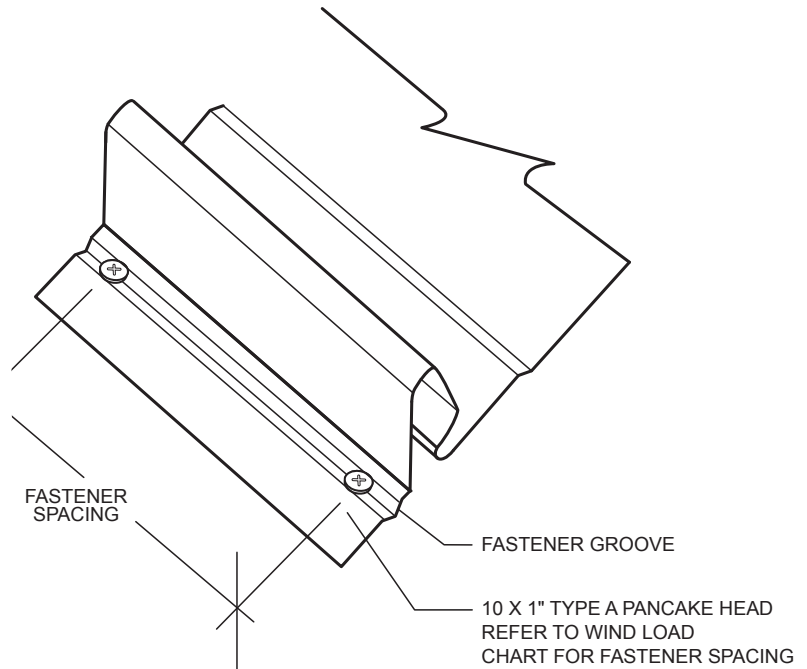
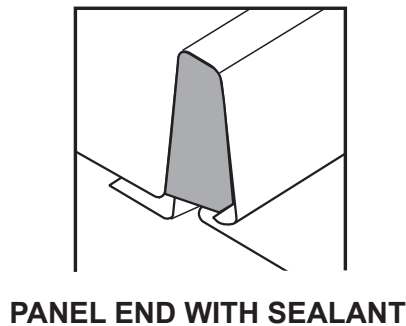

## FASTENER INSTALLATION

**NOTES:**

1. Panels are produced with a fastener groove to facilitate fastener placement.
2. Total sidelap engagement without spreading the panel rib is essential. Always check panel module at each end before installing fasteners.
3. Fill panel ends with urethane sealant.

# DETAILS

## RIDGE

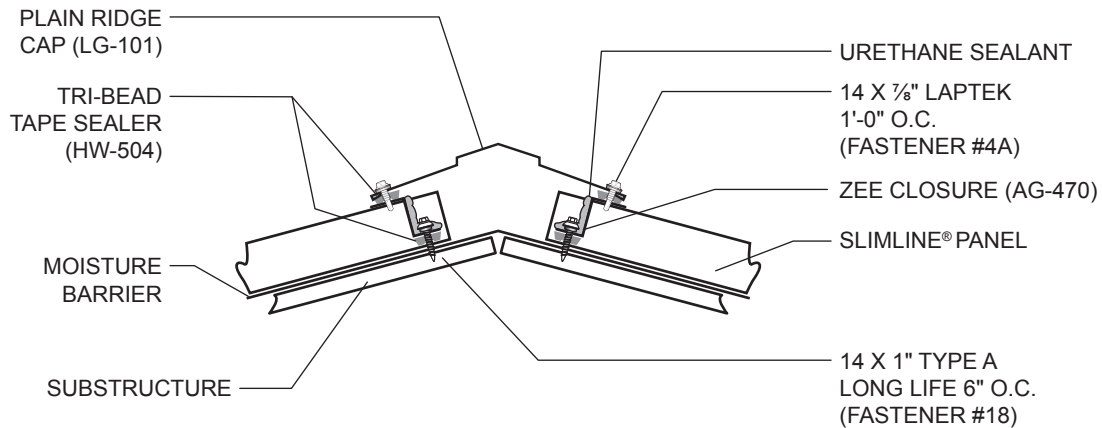

### CROSS SECTION OF PLAIN RIDGE CAP

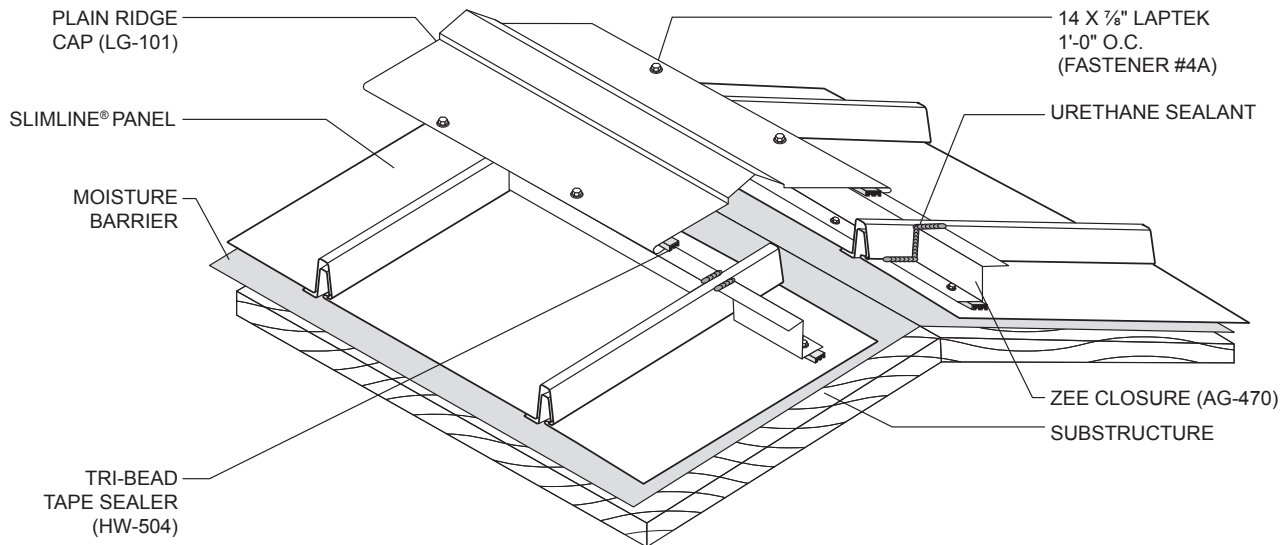

### ISOMETRIC VIEW OF RIDGE

**NOTES:**

1. Field cut Zee closures to fit panel width.
2. Install tri-bead tape sealer to bottom leg of Zee closures and attach to panels with four 14 X 1" Type A fasteners per panel (three fasteners for 12" panel). Vertical leg of Zee closure should be 3" from center of ridge.
3. Seal ends of Zee closures with urethane sealant.
4. Attach ridge flash to Zee closures with 14 X 7/8" Long Life Laptek at 1'-0" O.C.

# DETAILS

## HIP

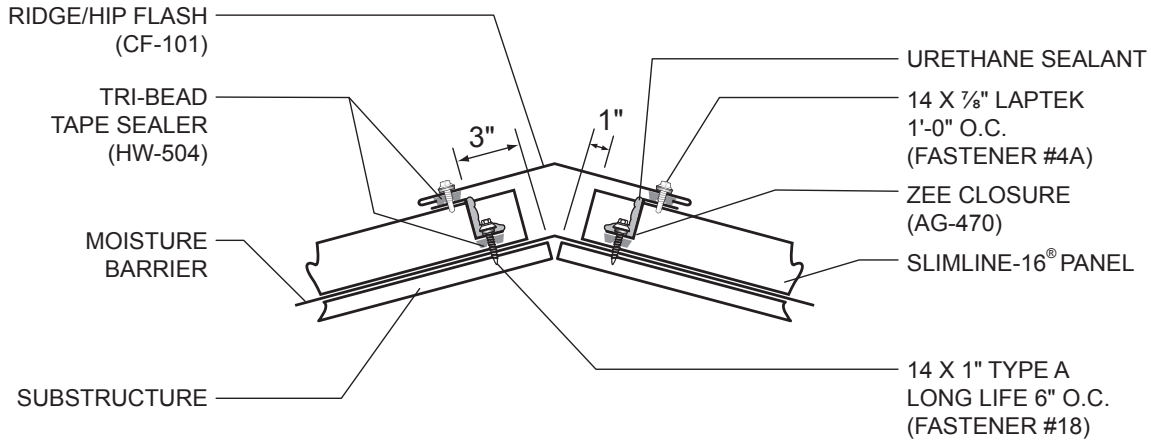

### CROSS SECTION OF HIP

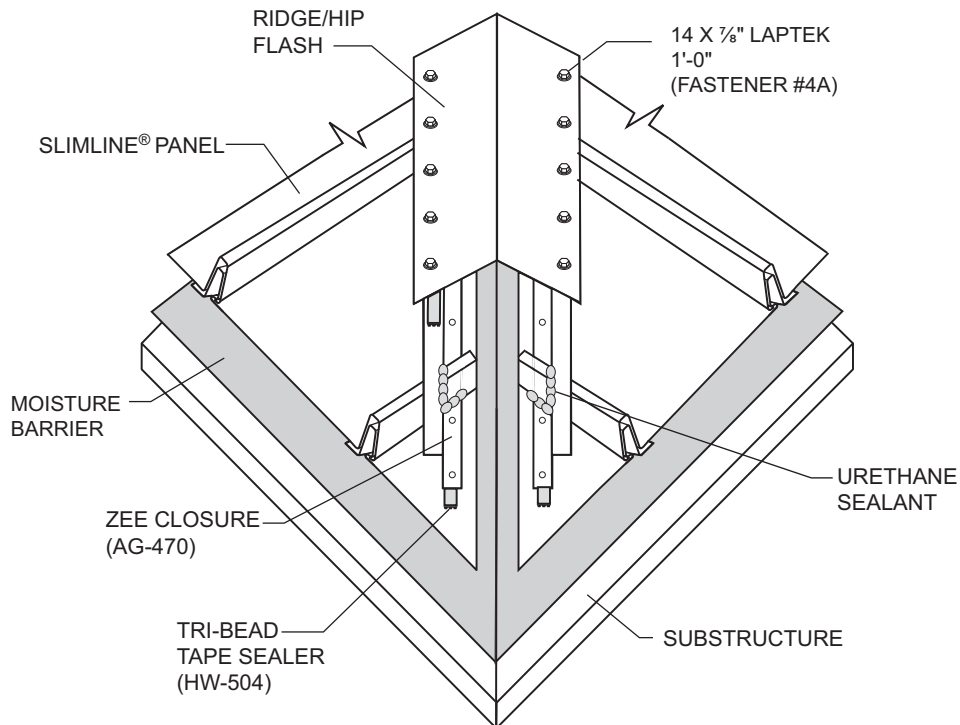

### ISOMETRIC VIEW OF HIP

#### NOTES:

1. Bevel cut and install panels to follow angle of hip.
2. Field cut Zee closures to fit panel bevel width.
3. Install tri-bead tape sealer to bottom leg of Zee closures and attach to panels with 14 X 1" Type A fasteners 6" O.C. maximum. Vertical leg of Zee closure should be 3" from center of hip.
4. Seal ends of Zee closures with urethane sealant.
5. Attach Hip Flash to Zee closures with 14 X 7/8" Long Life Laptek at 1'-0" O.C.

# DETAILS

## PEAK TRIM

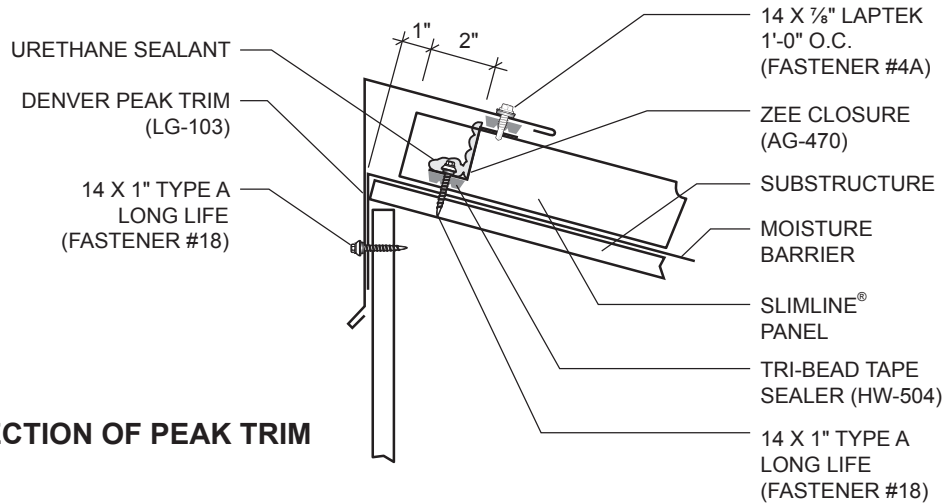

**CROSS SECTION OF PEAK TRIM**

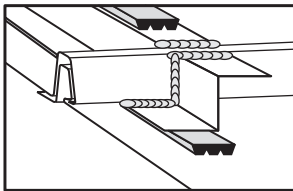

**SEALANT DETAIL**

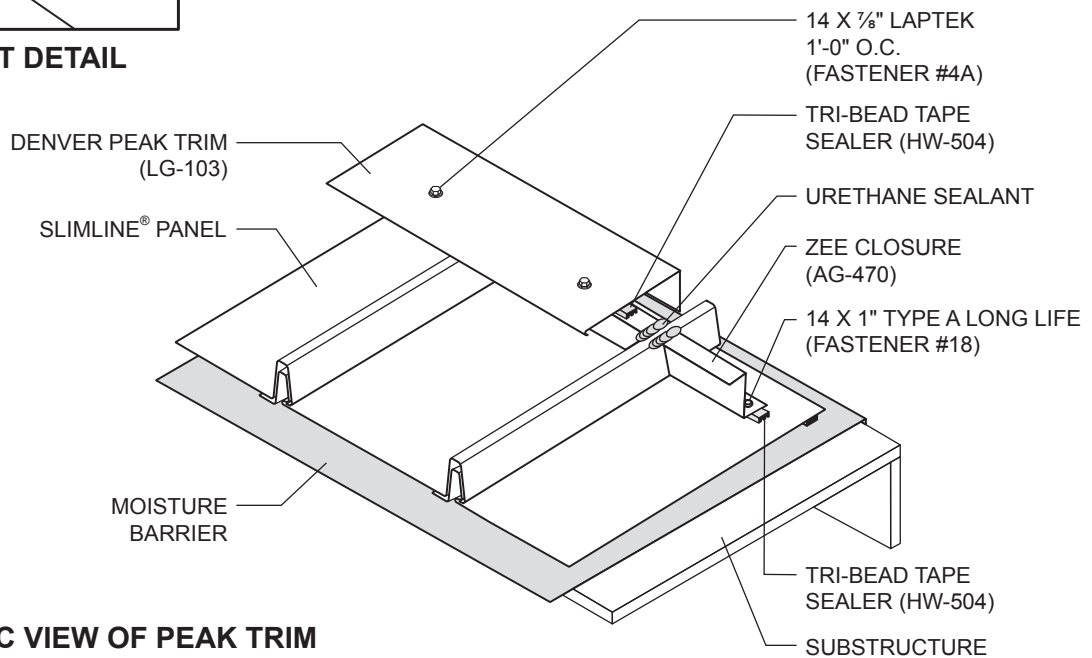

**ISOMETRIC VIEW OF PEAK TRIM**

**NOTES:**

1. Field cut Zee closures to fit panel width.
2. Install tri-bead tape sealer to bottom leg of Zee closures and attach to panels with four 14 X 1" Type A fasteners per panel (three fasteners for 12" panel). Vertical leg of Zee closure should be 3" from edge of peak.
3. Seal ends of Zee closures with urethane sealant.

# DETAILS

## EAVE

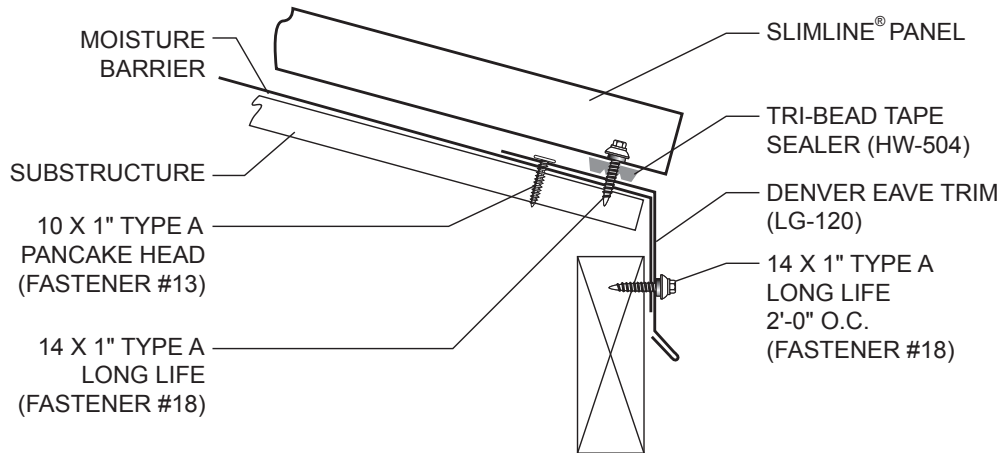

### CROSS SECTION OF EAVE WITH EXPOSED FASTENERS

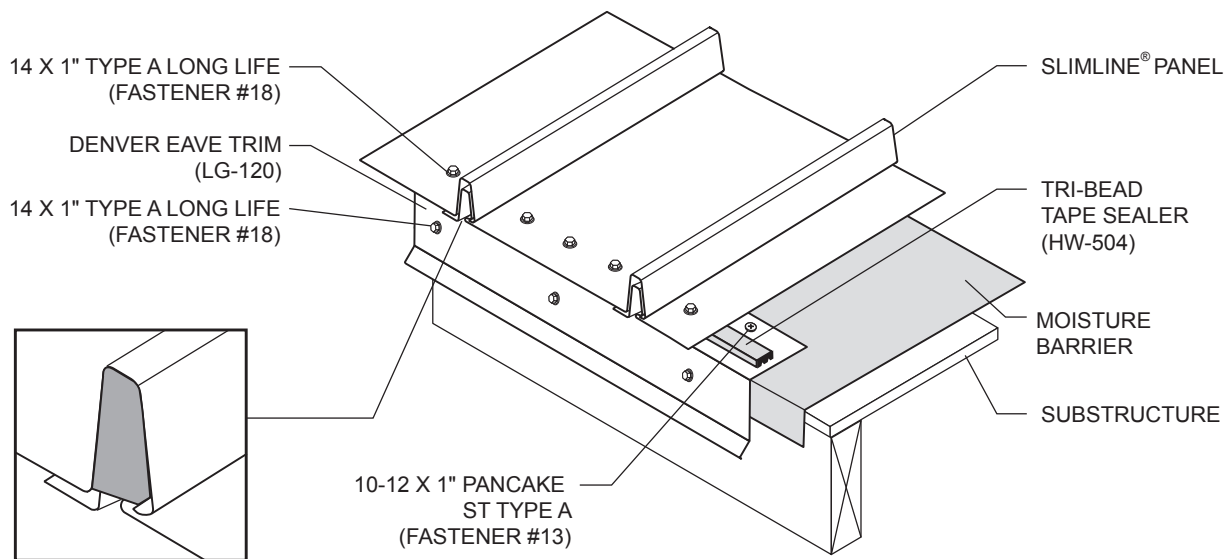

### PANEL END WITH SEALANT

### ISOMETRIC VIEW OF EAVE WITH EXPOSED FASTENERS

**NOTES:**

1. Attach eave trim to roof deck with two pancake head fasteners per 10' section.
2. Install tri-bead tape sealer along top leg of eave trim.
3. Attach panel at eave with four 14 X 1" Type A Long Life fasteners
4. Fill ends of panels with urethane sealant.

# DETAILS

# DETAILS

## RAKE

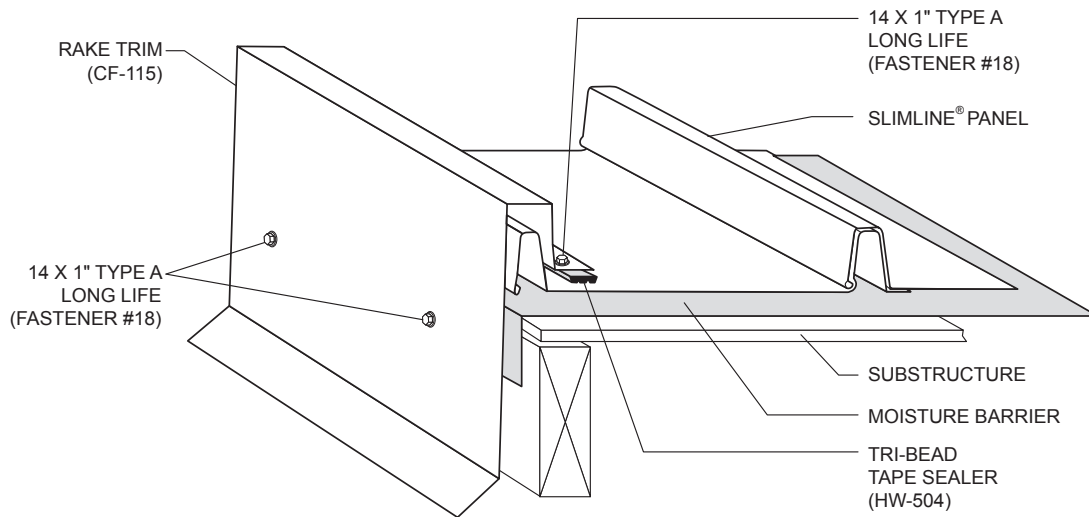
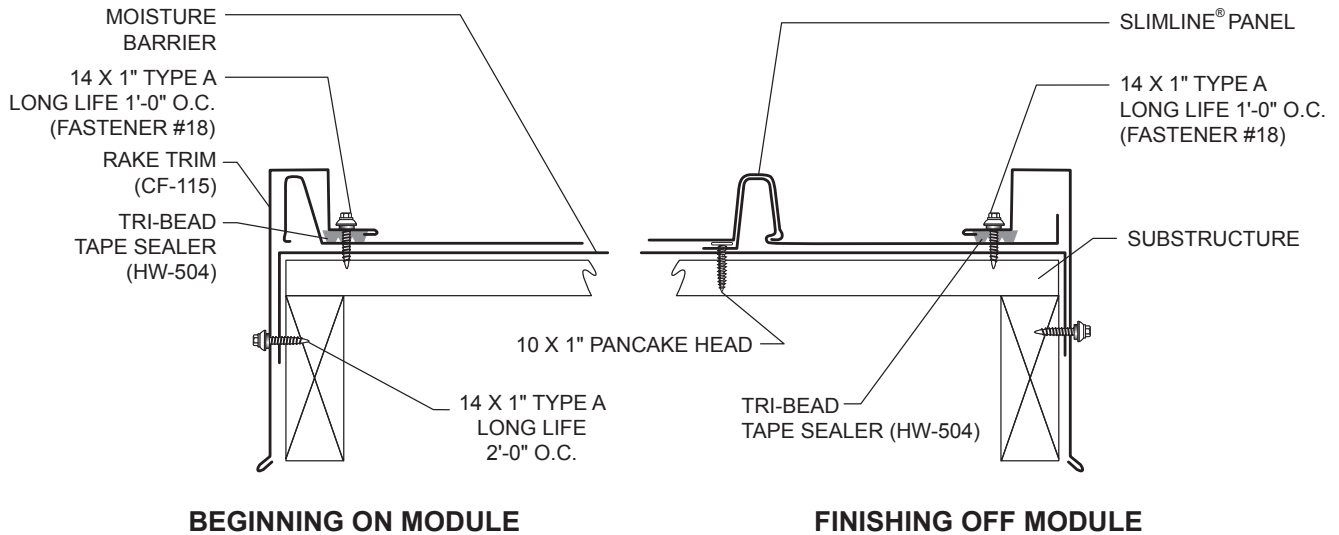

### ISOMETRIC VIEW OF BEGINNING ON MODULE

**NOTES:**

1. Install rake trim to roof with 14 X 1" Type A Long Life Fastener at 1'-0" O.C. Fasteners must go through tri-bead tape sealer.
2. When finishing off module, field bend a 1" leg up on panel before installing rake trim.

# DETAILS

## VALLEY

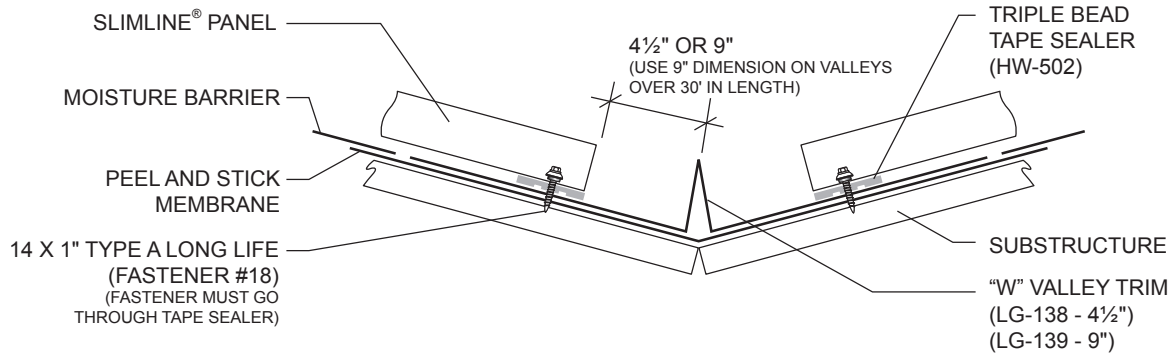

### CROSS SECTION OF VALLEY WITH EXPOSED FASTENERS

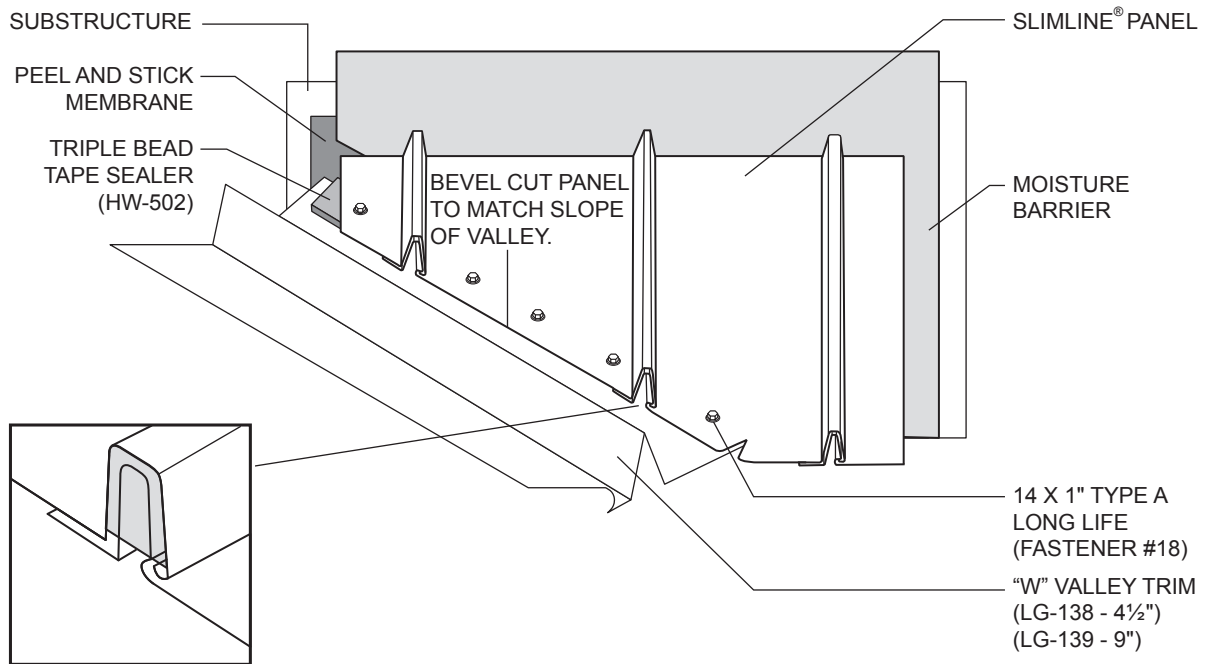

### PANEL END WITH SEALANT

### ISOMETRIC VIEW OF VALLEY WITH EXPOSED FASTENERS

**NOTES:**

1. For valleys 30' or less in length, use standard "W" valley trim (LG-138). For valleys over 30' in length use LG-139.
2. Apply triple-bead tape sealer to the valley trim parallel to the slope of the valley. Lower edge of tape sealer should be even with edge of roof panel.
3. Bevel cut panels to fit slope of valley.
4. Fasten panels to valley with 14 X 1" Type A Long Life fasteners at 4" O.C. maximum. Fasteners must go through tape sealer.
5. Fill ends of panels with urethane sealant.

# DETAILS

## SIDE WALL

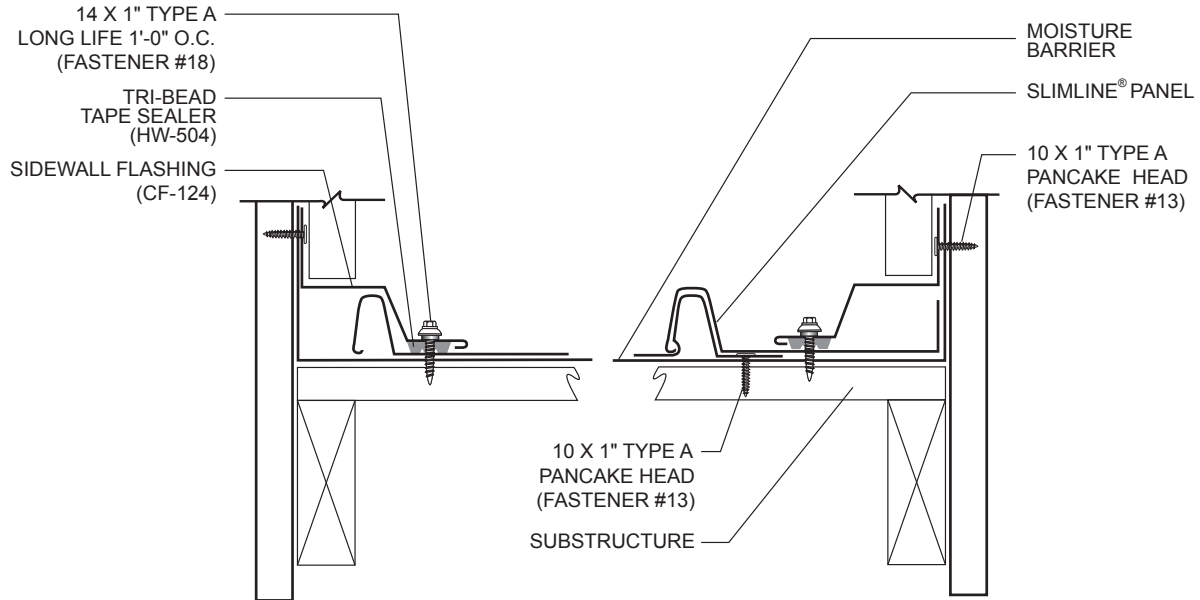

**BEGINNING ON MODULE**

**FINISHING OFF MODULE**

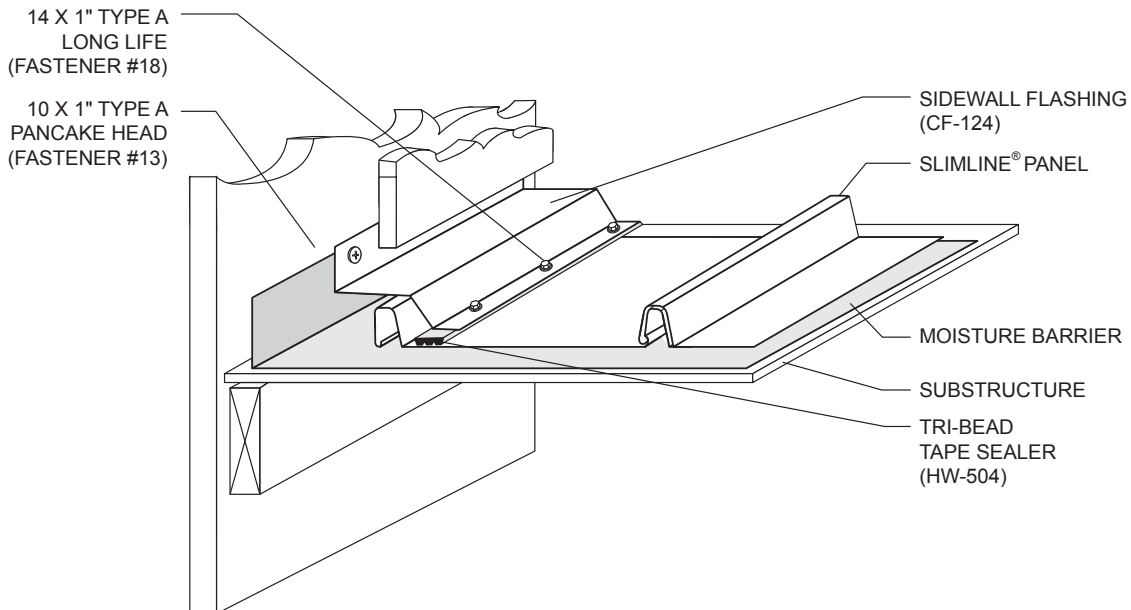

### ISOMETRIC VIEW OF BEGINNING ON MODULE

**NOTES:**

1. If roof finishes on module, proceed to Step 2. If roof finishes off module, field bend a 1" leg up on panel before proceeding to Step 2.
2. Install Sidewall Flashing to roof panels with 14 X 1" Type A Long Life Fasteners at 1'-0" O.C. Fasteners must go through tri-bead tape sealer. Top leg of flash may be fastened to substrate as needed to hold in place before siding is installed.

# DETAILS

## ENDWALL

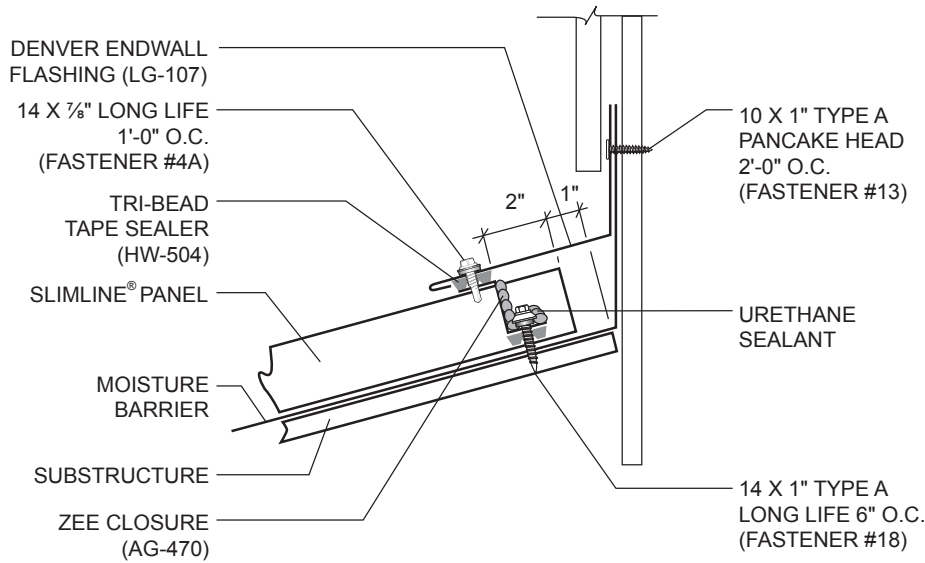

### CROSS SECTION OF ENDWALL

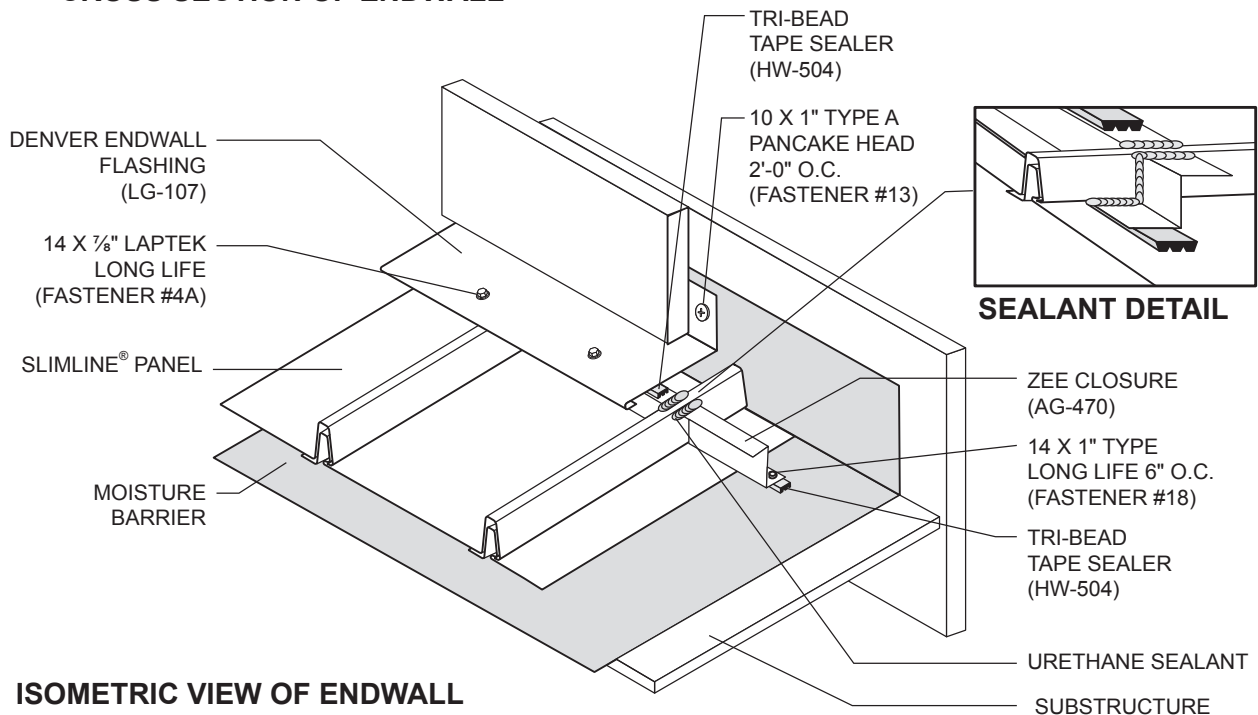

### ISOMETRIC VIEW OF ENDWALL

**NOTES:**

1. Field cut Zee closures to fit panel width.
2. Install tri-bead tape sealer to bottom leg of Zee closures and attach to panels with four 14 X 1" Type A fasteners per panel (three fasteners for 12" panel). Vertical leg of Zee closure should be 3" from top of roof deck.
3. Seal ends of Zee closures with urethane sealant.
4. Attach endwall flash to Zee closures with 14 X 7/8" Long Life Laptek at 1'-0" O.C. Top leg of flash may be fastened to substructure as needed to hold in place before siding is installed.

# DETAILS

## RIDGE

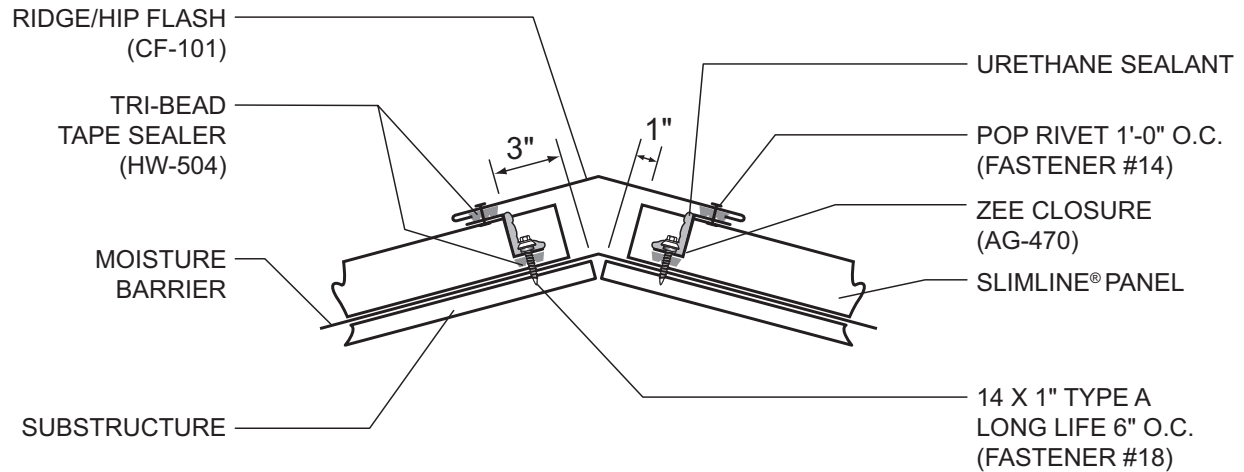

**CROSS SECTION OF RIDGE**

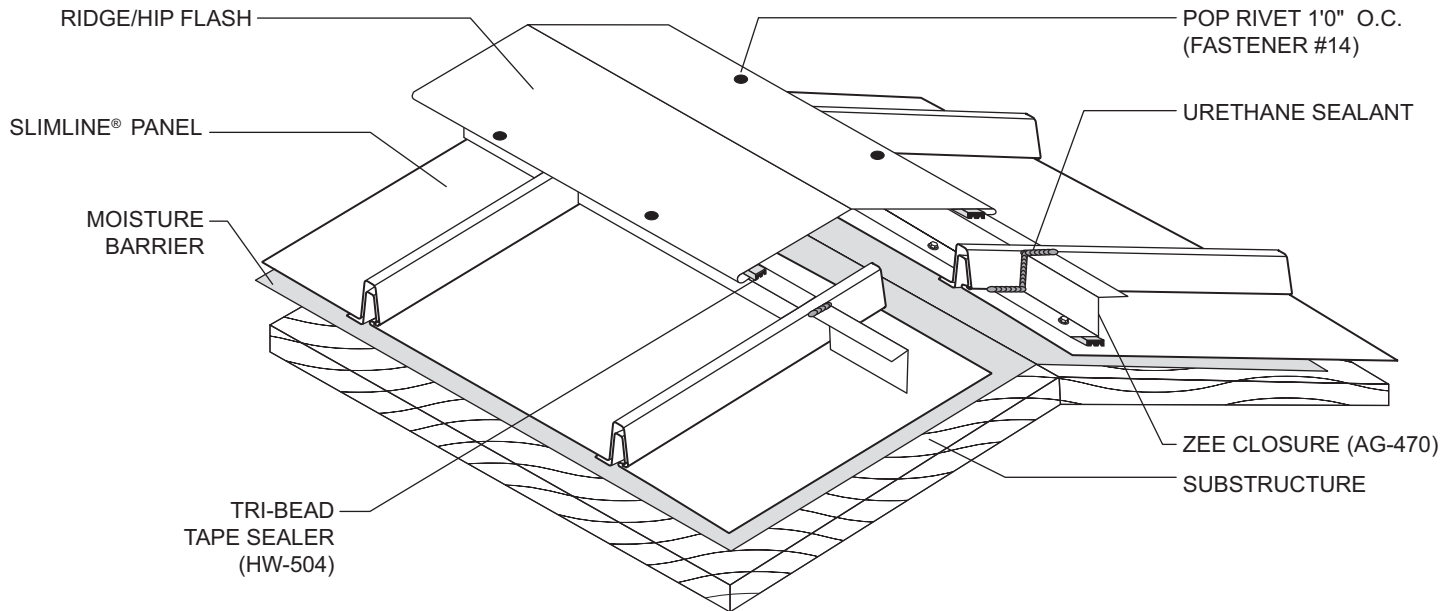

**ISOMETRIC VIEW OF RIDGE**

**NOTES:**

1. Field cut Zee closures to fit panel width.
2. Install tri-bead tape sealer to bottom leg of Zee closures and attach to panels with four 14 X 1" Type A fasteners per panel (three fasteners for 12" panel). Vertical leg of Zee closure should be 3" from center of ridge.
3. Seal ends of Zee closures with urethane sealant.
4. Attach ridge flash to Zee closures with pop rivets at 1'-0" O.C.

# DETAILS

## HIP

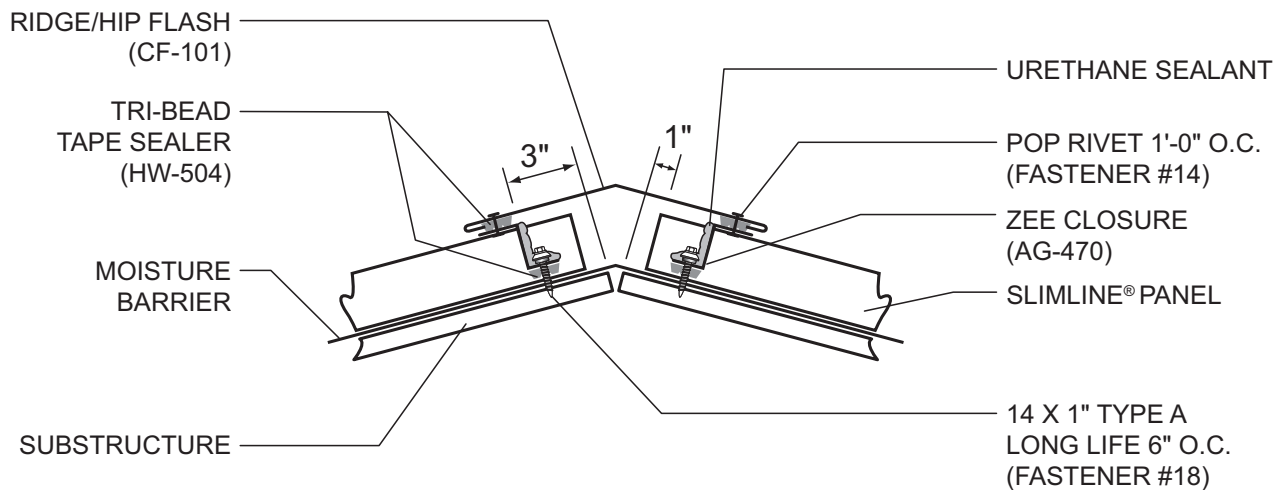

### CROSS SECTION OF HIP

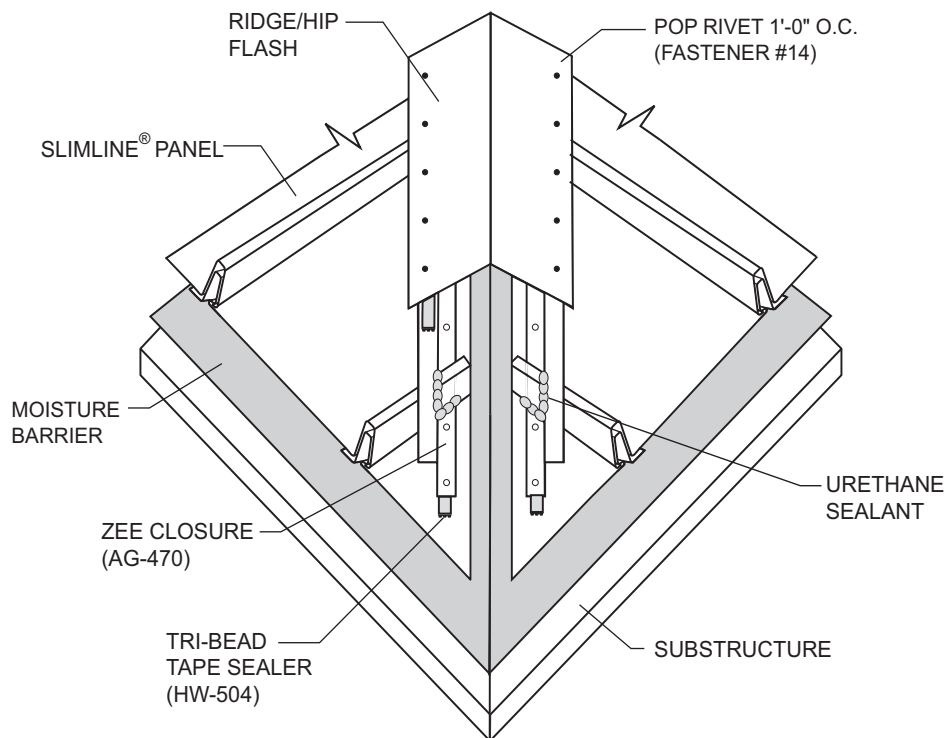

### ISOMETRIC VIEW OF HIP

**NOTES:**

1. Bevel cut and install panels to follow angle of hip.
2. Field cut Zee closures to fit panel bevel width.
3. Install tri-bead tape sealer to bottom leg of Zee closures and attach to panels with 14 X 1" Type A fasteners 6" O.C. maximum. Vertical leg of Zee closure should be 3" from center of hip.
4. Seal ends of Zee closures with urethane sealant.
5. Attach Hip Flash to Zee closures with pop rivets 1'-0" O.C.

# DETAILS

## PEAK TRIM

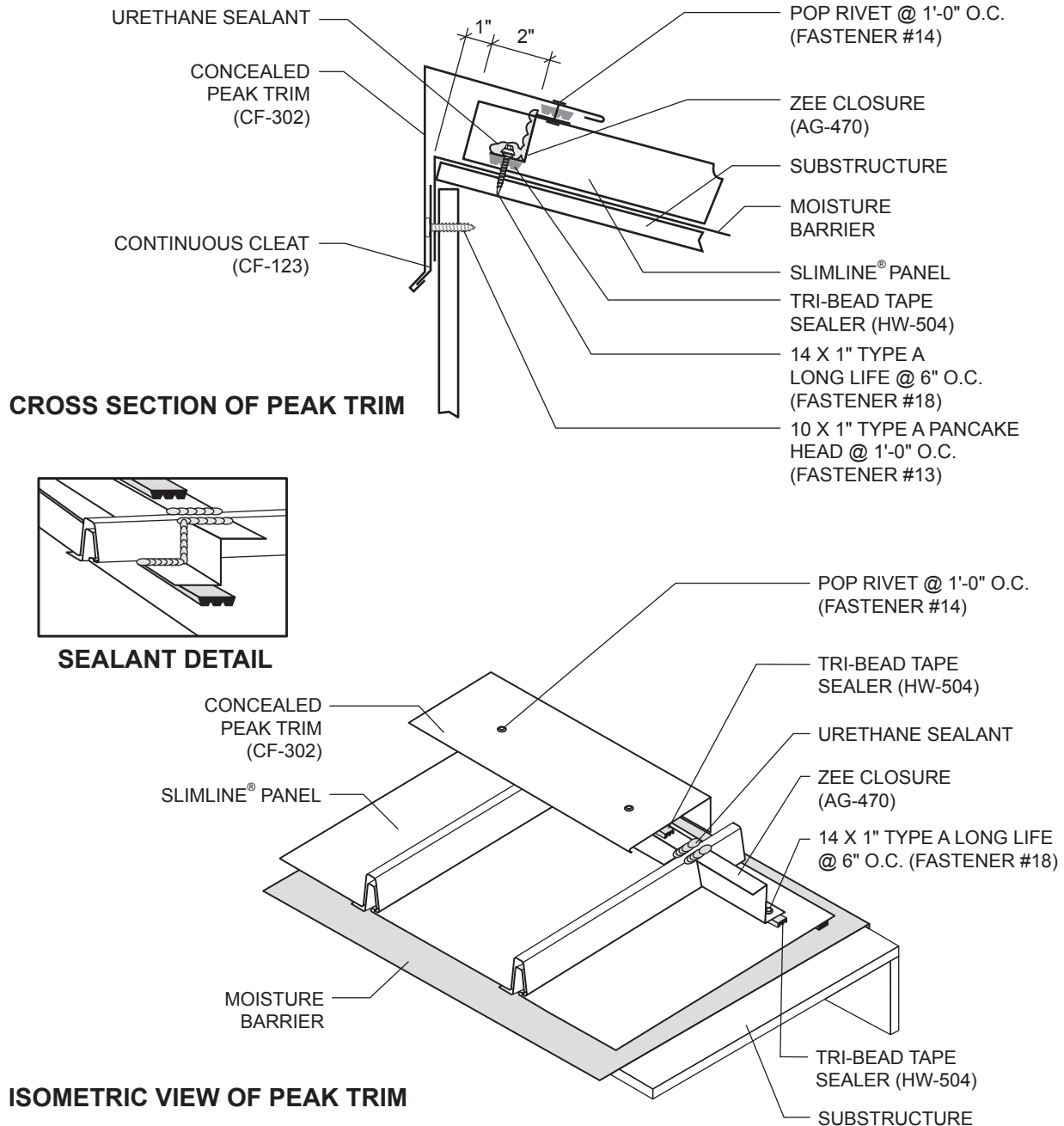

**CROSS SECTION OF PEAK TRIM**

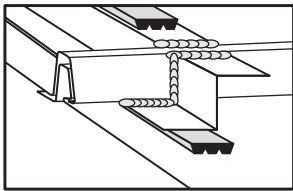

**SEALANT DETAIL**

**ISOMETRIC VIEW OF PEAK TRIM**

**NOTES:**

1. Field cut Zee closures to fit panel width.
2. Install tri-bead tape sealer to bottom leg of Zee closures and attach to panels with four 14 X 1" Type A fasteners per panel (three fasteners for 12" panel). Vertical leg of Zee closure should be 3" from edge of peak.
3. Seal ends of Zee closures with urethane sealant.
4. Install continuous cleat to wall with 10x1" pancake head screws at panel ribs.
5. Hook open item of concealed peak trim onto continuous cleat and attach top leg of trim to Zee closures with pop rivets at 1'-0" O.C.

# DETAILS

## FIELD HEMMING PANEL END

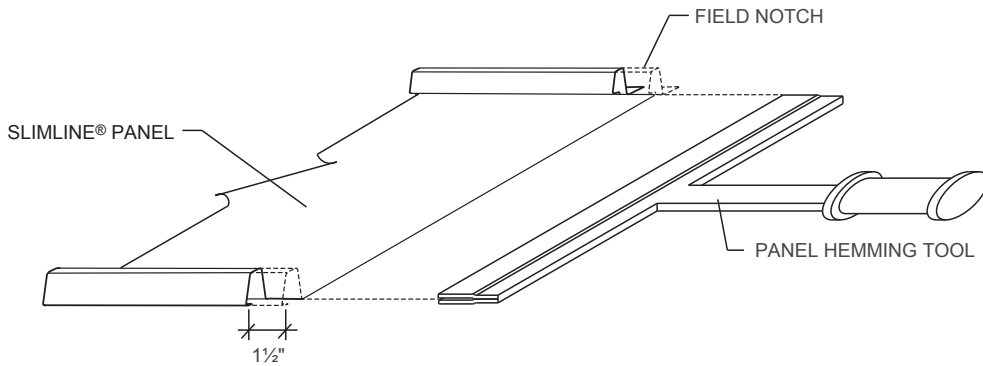

## NOTCHING PANEL END

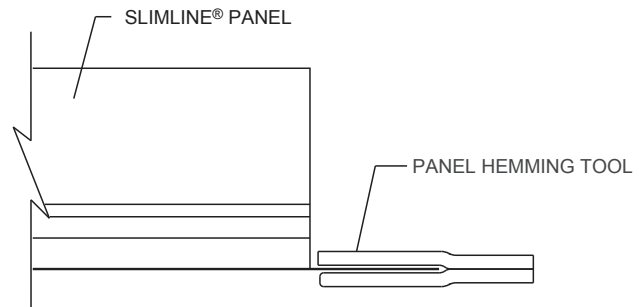

## ENGAGING HEMMING TOOL

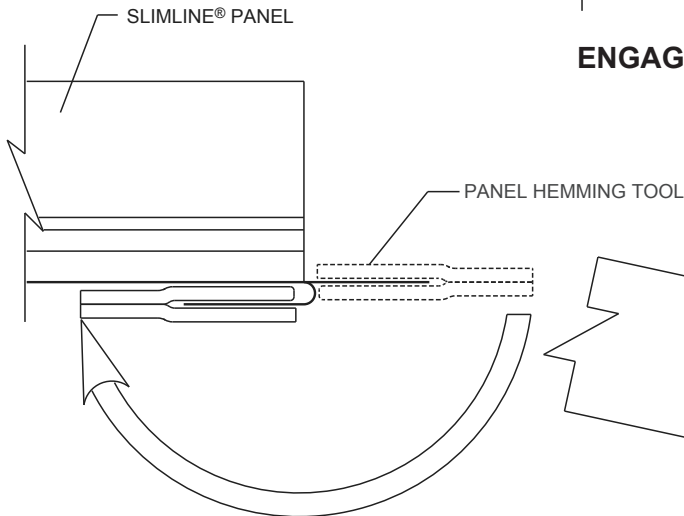

## FORMING OPEN HEM

## PANEL ENGAGEMENT

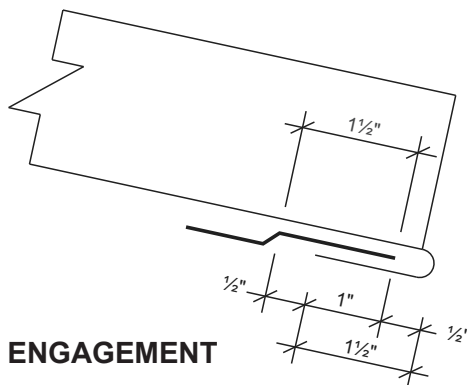

**NOTES:**

1. Field notch male and female legs of panel 1 1/2".
2. Engage panel hemming tool onto protruding panel.
3. Bend panel down to form an open hem.
4. Hem may be tightened with a pair of vise grip "duck bills."

# DETAILS

## VALLEY WITH OFFSET CLEAT

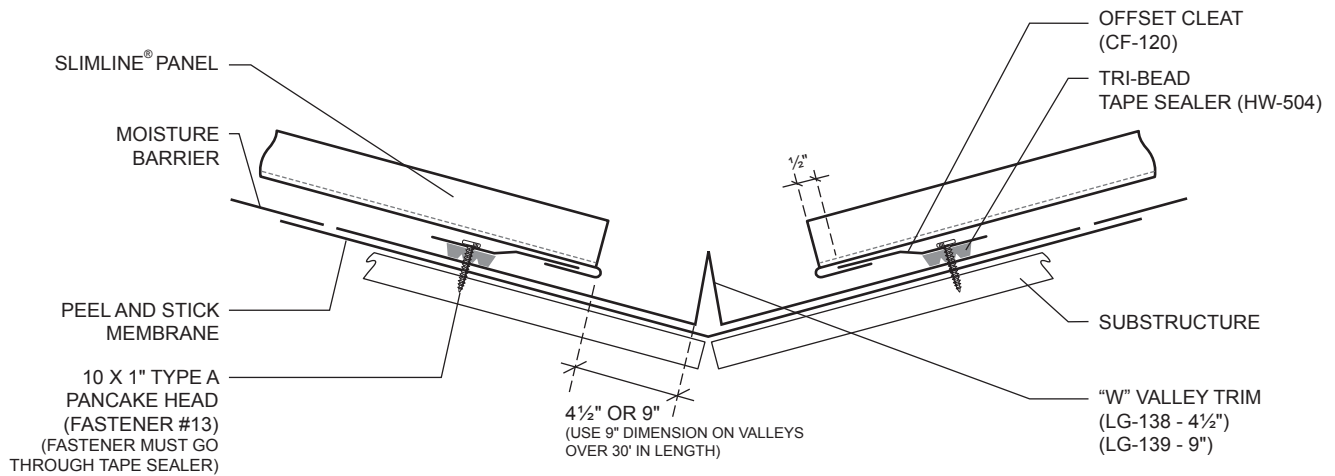

### CROSS SECTION OF VALLEY

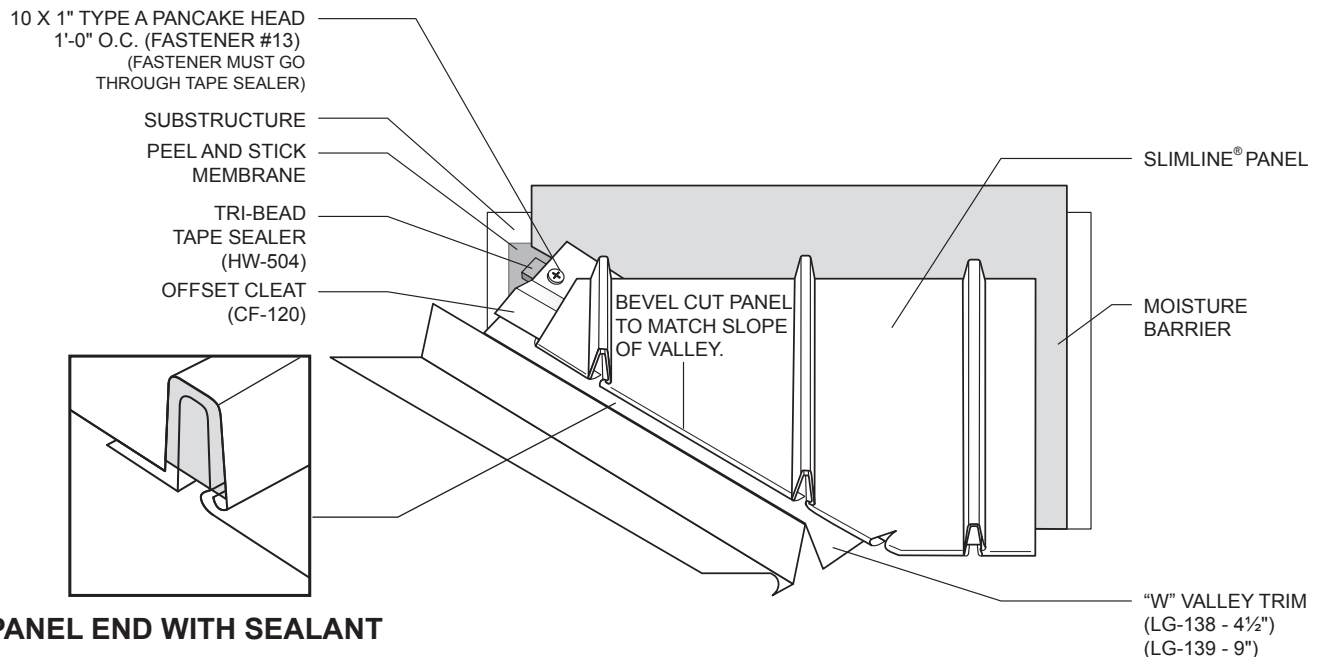

### PANEL END WITH SEALANT

### ISOMETRIC VIEW OF ALTERNATE VALLEY

#### NOTES:

1. Offset cleat is installed continuous along slope of valley over tri-bead tape sealer with 10 X 1" Type A Pancake Head Fastener at 1'-0" O.C. **Fasteners must go through tape sealer.**
2. Add 1 1/2" to panel length for the panel hem. See page S34 for Hemming Detail.
3. Fill ends of panels with urethane sealant.

# DETAILS

## EAVE WITH OFFSET CLEAT

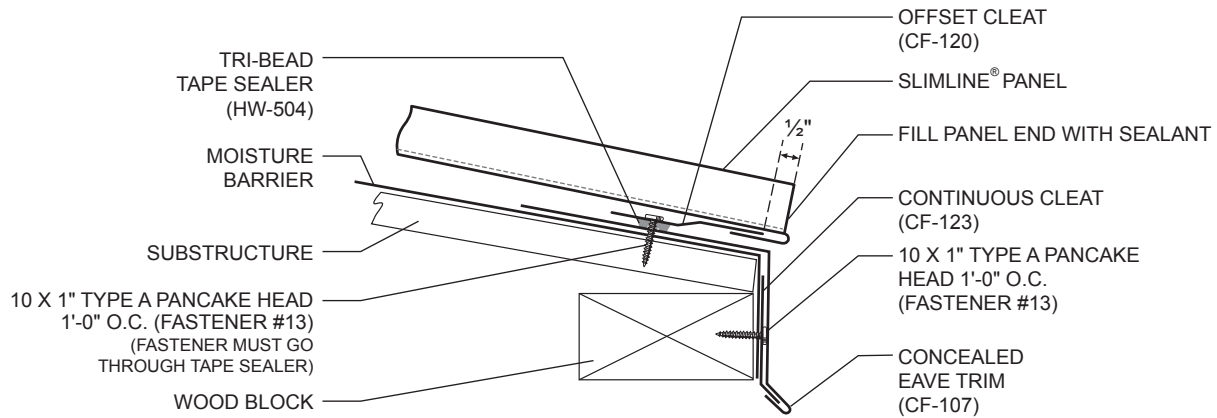

### CROSS SECTION OF EAVE WITH OFFSET CLEAT

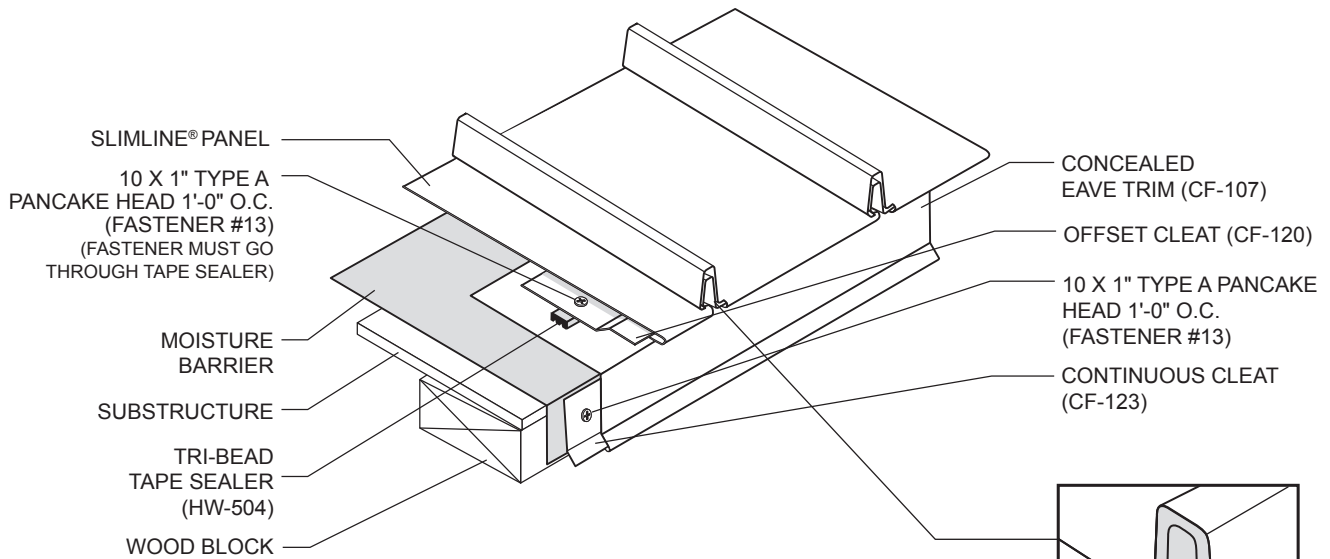

### ISOMETRIC VIEW OF ALTERNATE EAVE WITH OFFSET CLEAT

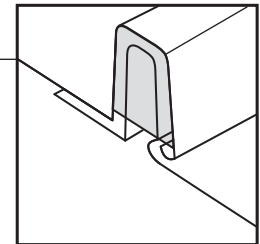

**PANEL END WITH SEALANT**

**NOTES:**

1. Where load conditions permit, install first panel fastener 12" from eave for best appearance. Consult a design professional or engineer to ensure compliance with local load and code requirements.
2. Attach offset cleat to substructure with 10 X 1" Type A Pancake Head Fastener at 1'-0" O.C.
3. Add 1/2" to panel length for the panel hem. See Page S34 for Hemming Detail.
4. Fill ends of panels with urethane sealant.

# DETAILS

## EAVE TRIM WITH DRIP EDGE

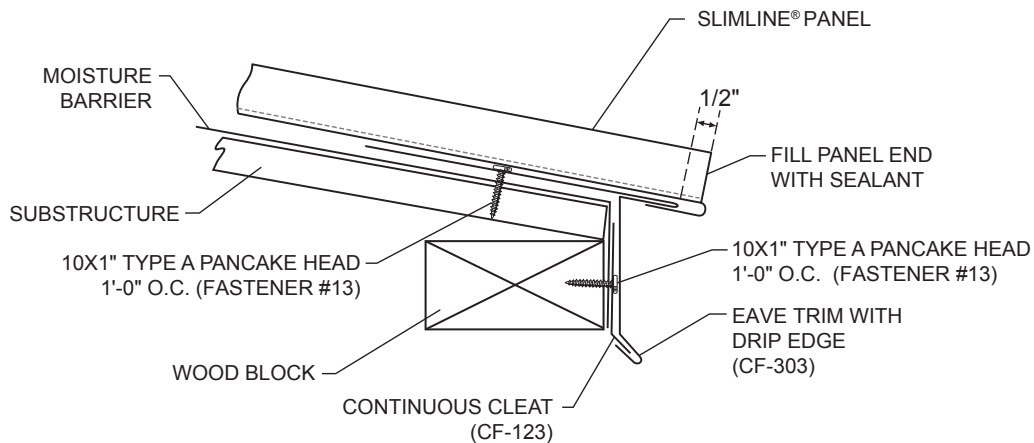

### CROSS SECTION OF EAVE TRIM WITH DRIP EDGE

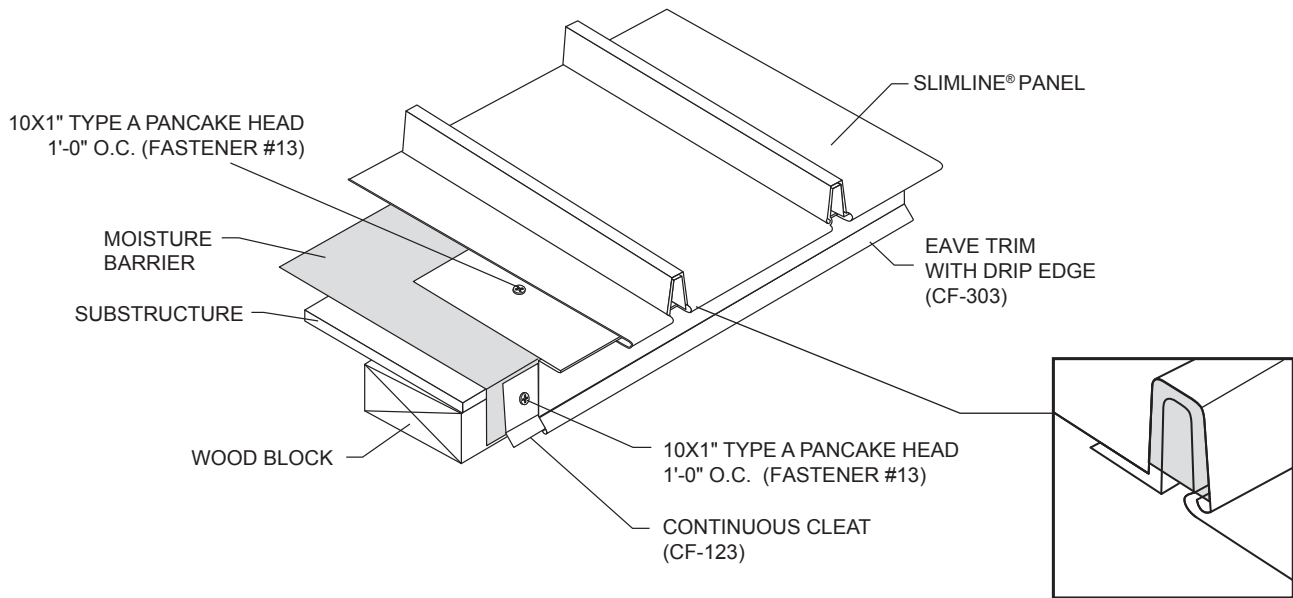

### ISOMETRIC VIEW OF EAVE TRIM WITH DRIP EDGE

### PANEL END WITH SEALANT

**NOTES:**

1. Where load conditions permit, install first panel fastener 12" from eave for best appearance. Consult a design professional or engineer to ensure compliance with local load and code requirements.
2. Attach offset cleat to substructure with 10 X 1" Type A Pancake Head Fastener at 1'-0" O.C.
3. Add 1/2" to panel length for the panel hem. See Page S34 for Hemming Detail.
4. Fill ends of panels with urethane sealant.

# DETAILS

## RAKE

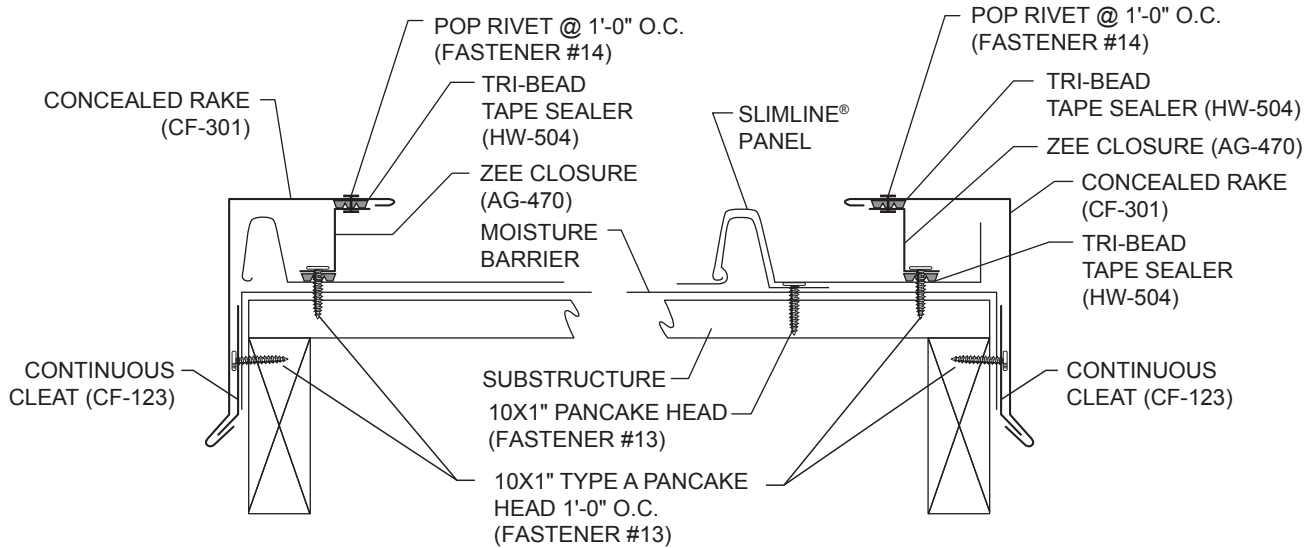

**BEGINNING ON MODULE**

**FINISHING OFF MODULE**

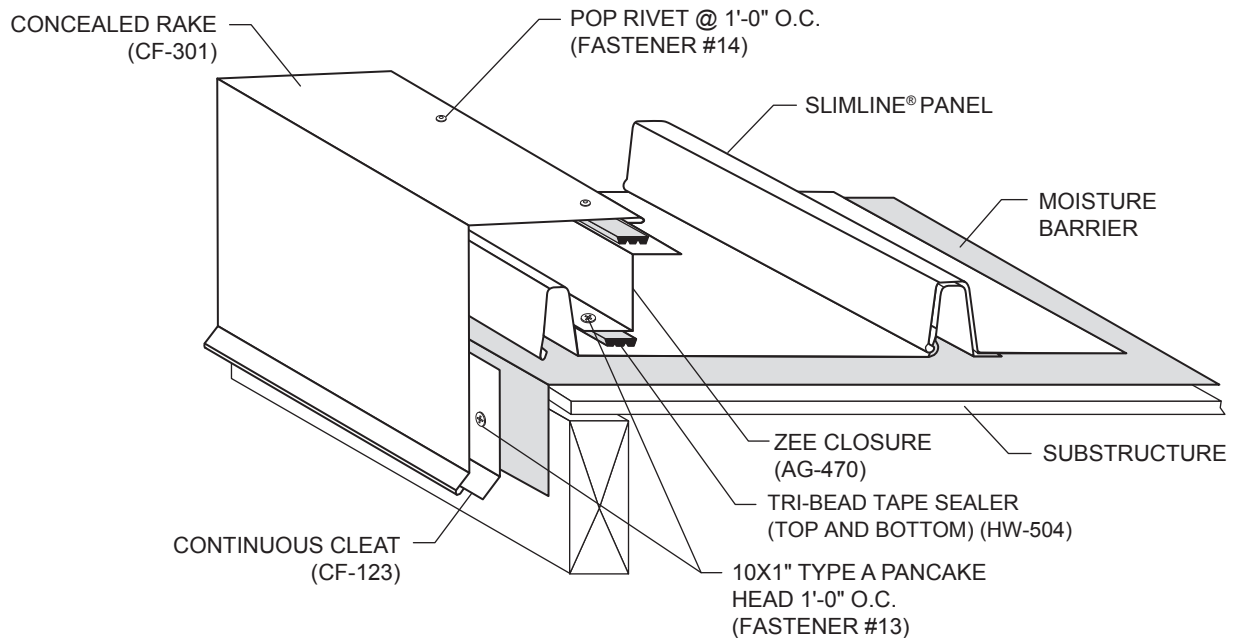

**ISOMETRIC VIEW OF BEGINNING ON MODULE**

**NOTES:**

1. Apply Tri-Bead Tape Sealer to bottom of Zee Closure and attach to substructure with 10x1" pancake head screws at 1'-0" on center.
2. Attach rake trim to Zee Closure with pop rivets at 1'-0" O.C.
3. When finishing off module, field bend a 1" leg up on panel before installing rake trim.

# DETAILS

## SIDE WALL

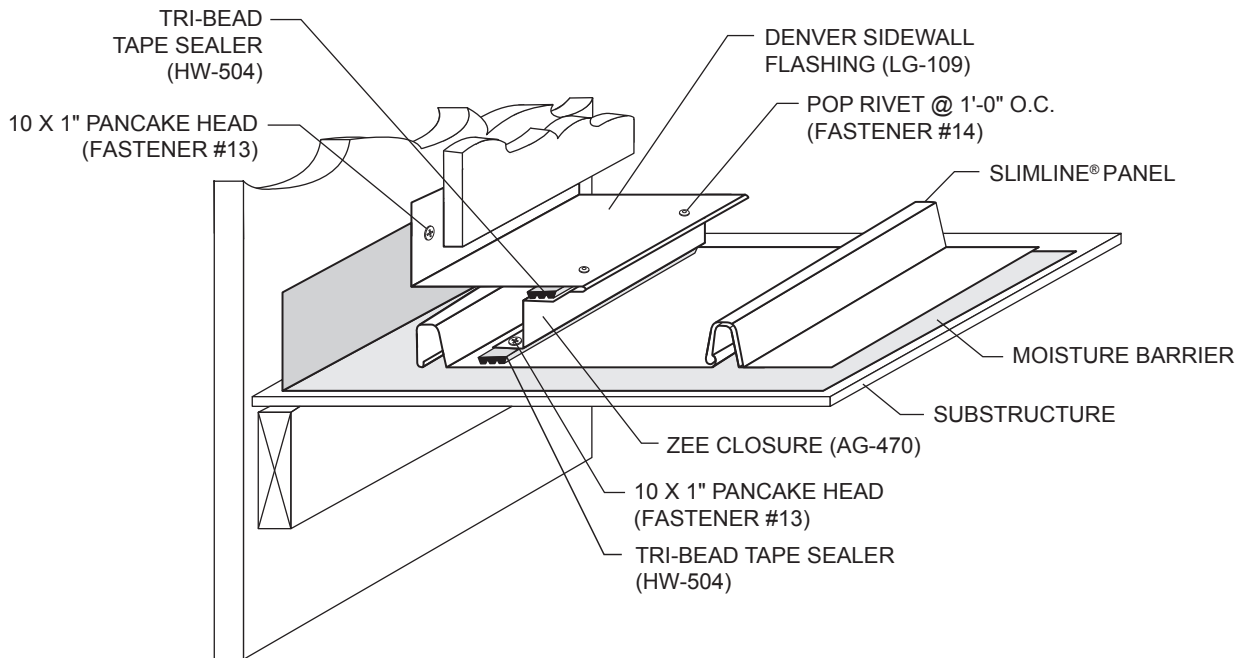
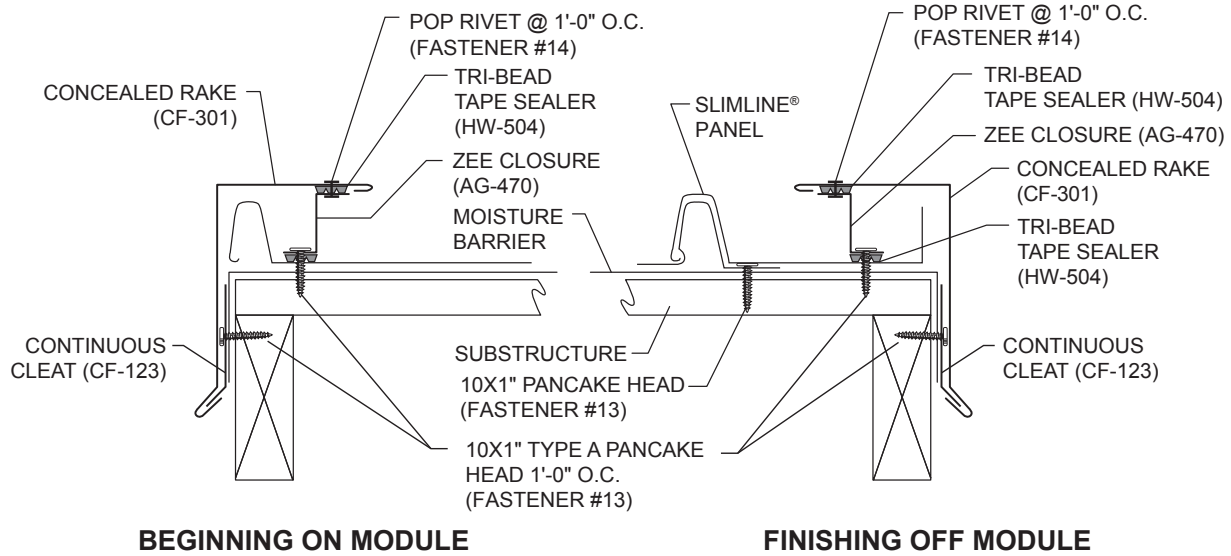

### ISOMETRIC VIEW OF BEGINNING ON MODULE

#### NOTES:

1. Apply Tri-Bead Tape Sealer to bottom of Zee Closure and attach to substructure with 10x1" pancake head screws at 1'-0" on center.
2. Attach sidewall flashing to Zee Closure with pop rivets at 1'-0" O.C.
3. When finishing off module, field bend a 1" leg up on panel before installing sidewall flashing.

# DETAILS

## ENDWALL

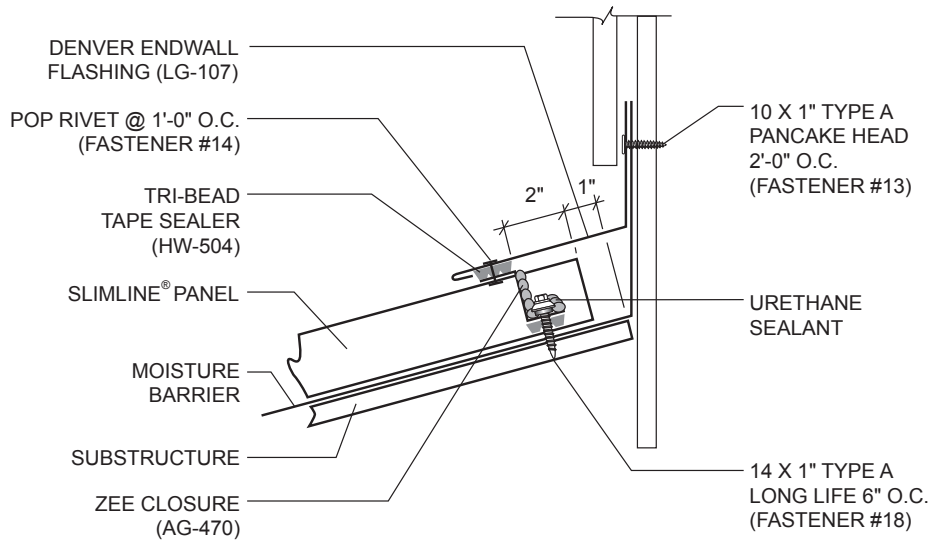

### CROSS SECTION OF ENDWALL

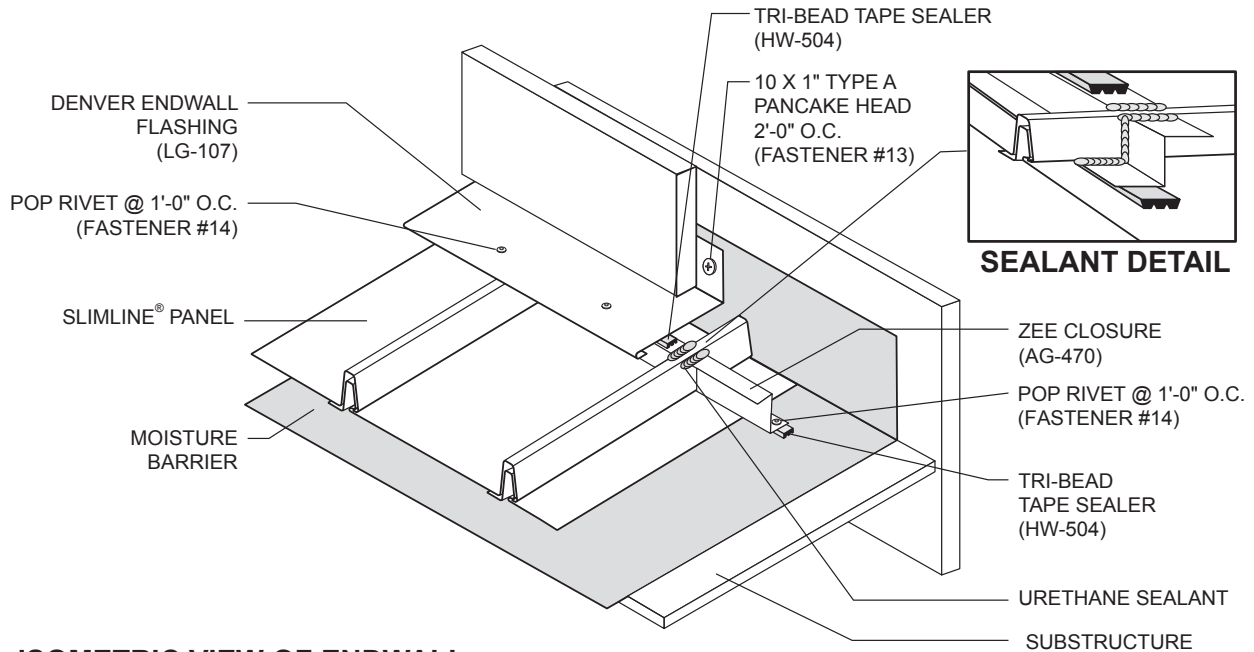

### ISOMETRIC VIEW OF ENDWALL

**NOTES:**

1. Field cut Zee closures to fit panel width.
2. Install tri-bead tape sealer to bottom leg of Zee closures and attach to panels with four 14 X 1" Type A fasteners per panel (three fasteners for 12" panel). Vertical leg of Zee closure should be 3" from top of roof deck.
3. Seal ends of Zee closures with urethane sealant.
4. Attach endwall flash to Zee closures with pop rivets at 1'-0" O.C. Top leg of flash may be fastened to substructure as needed to hold in place before siding is installed.

# DETAILS

## ROOF TRANSITION

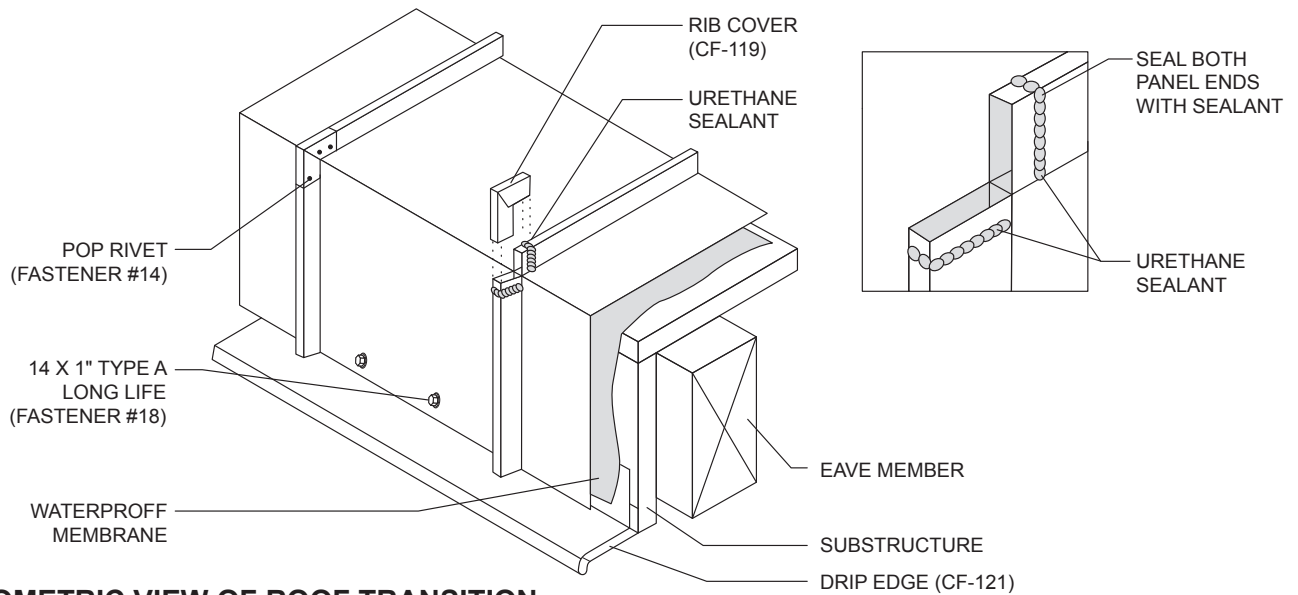
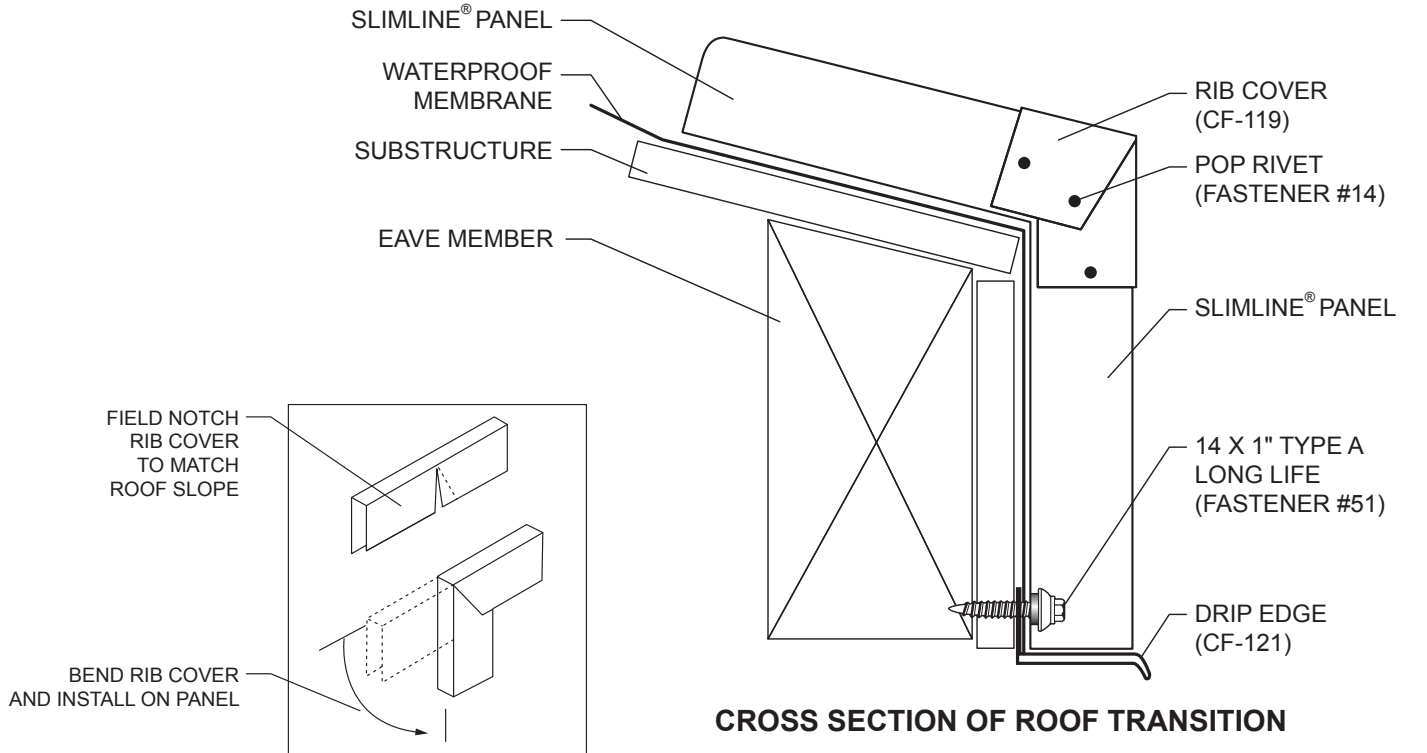

**NOTES:**

1. Lap Waterproof Membrane on outside of Drip Edge.
2. Field cut legs of panels and bend to required angle.
3. Fill both exposed ends of panels with urethane sealant.
4. Field notch rib cover to allow it to bend to the proper angle.
5. Field apply a bead of sealant over rib before applying rib cover.

# DETAILS

## SLOPE CHANGE - FIXED EAVE

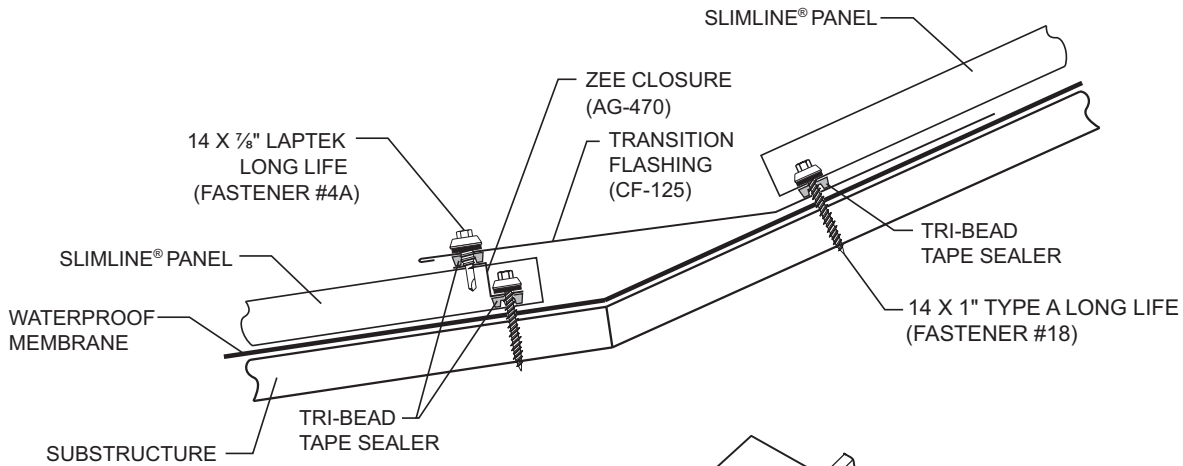

### CROSS SECTION OF SLOPE CHANGE

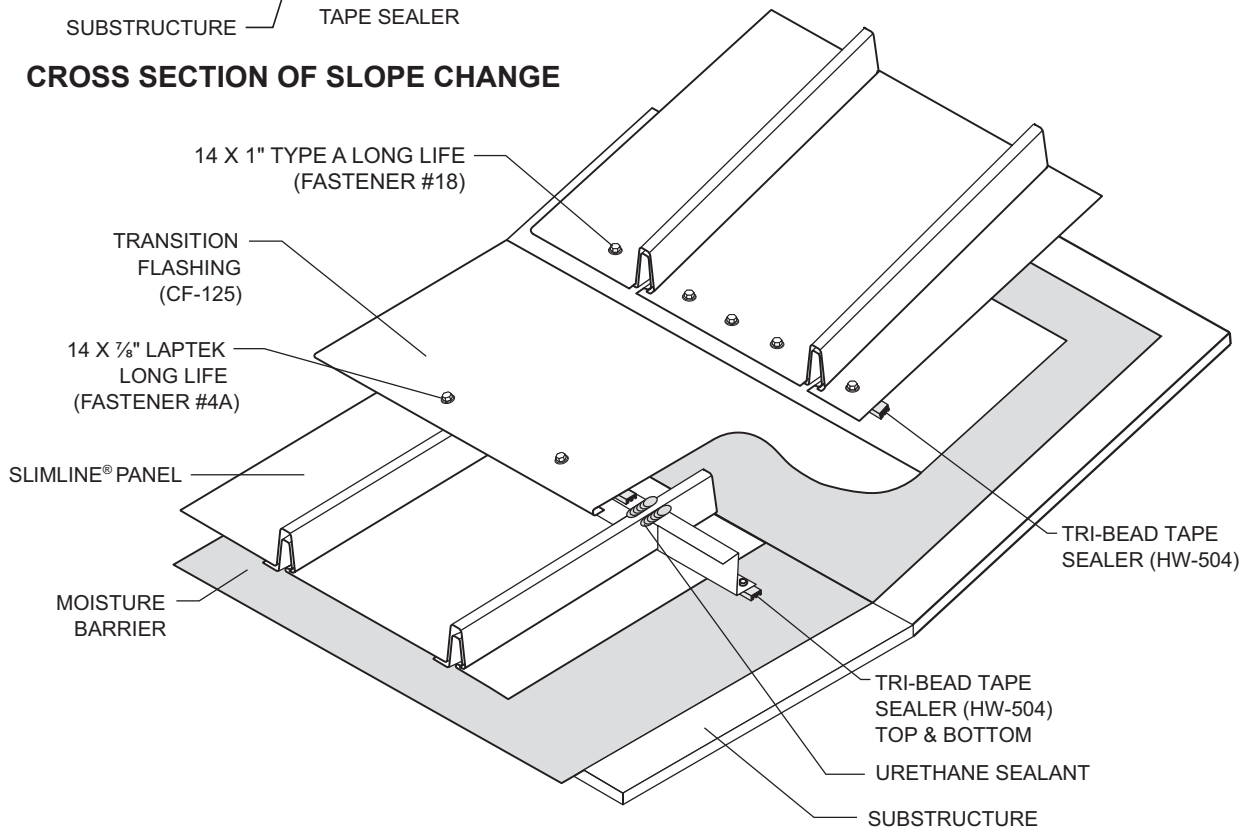

### ISOMETRIC VIEW OF SLOPE CHANGE

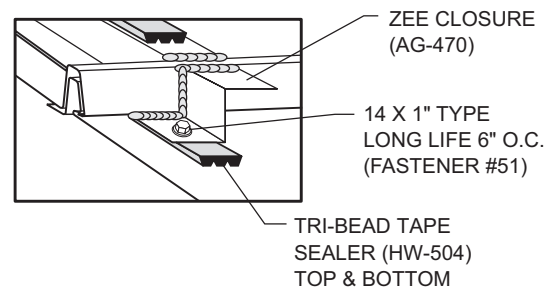

# DETAILS

## SLOPE CHANGE - FLOATING EAVE

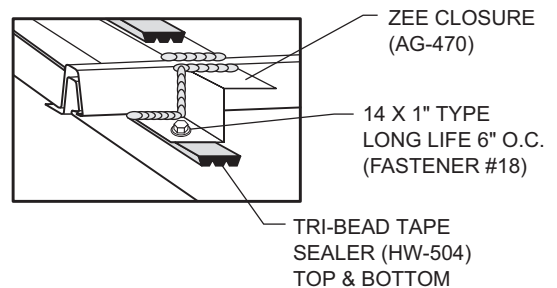
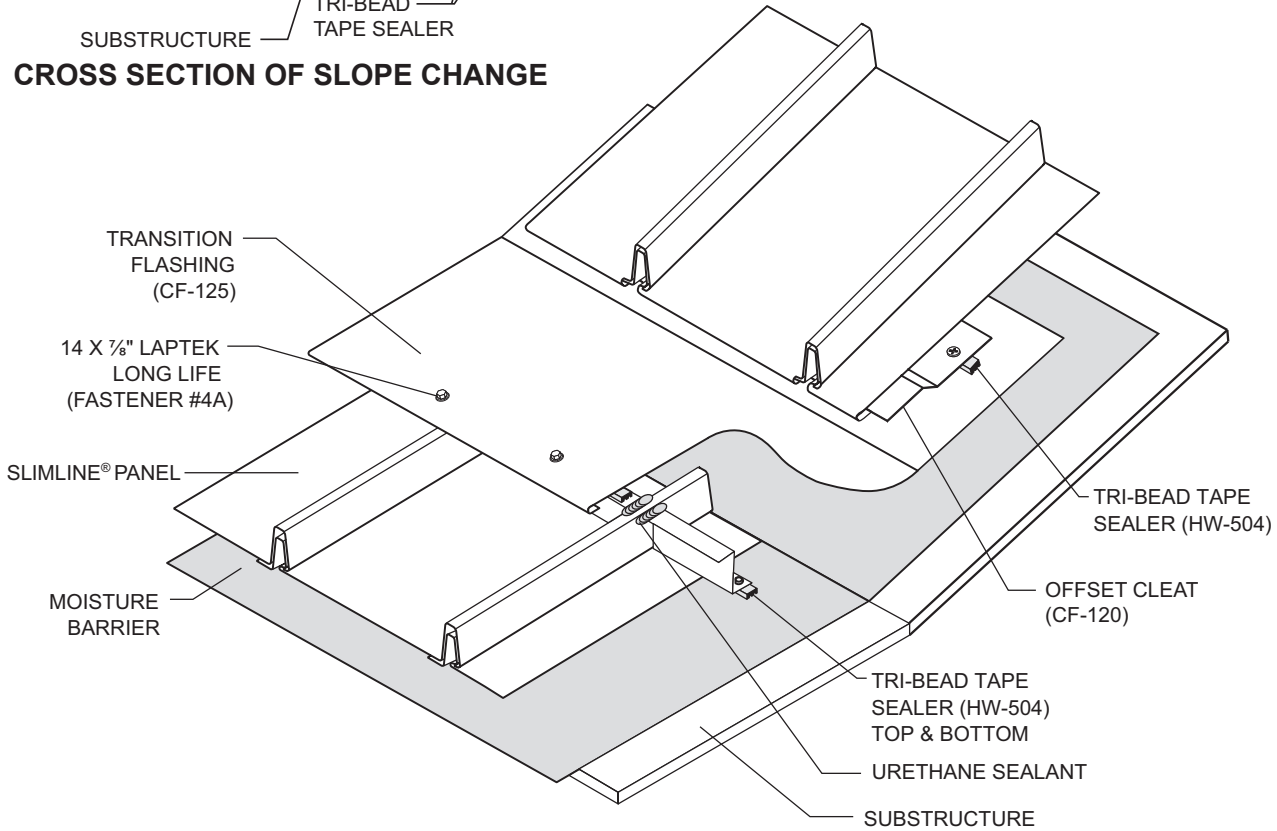
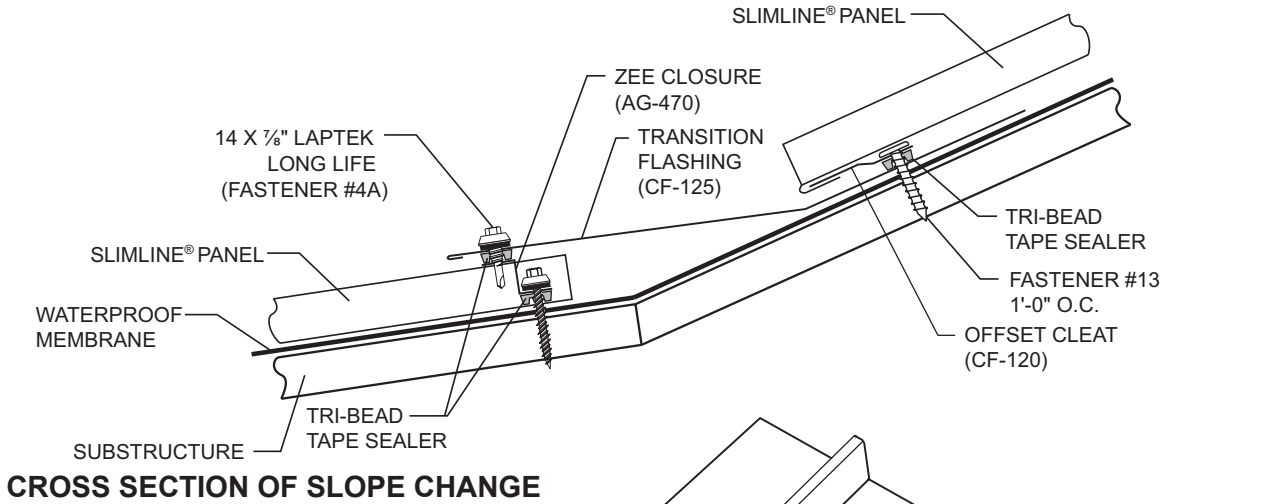

# DETAILS

## PROFILE VENT

1. Install your metal roofing panel according to manufacturer's instructions. Apply mastic above and below pre-drilled holes in the clip. Before installing ProfileVent, insert #14A screw through the large down-slope access hole in top of the Ridge Cap Anchor Clip.

2. Lift the back end of clip. Slip ProfileVent under the clip. Push clip back down and insert another #14A screw in the up-slope hole.

3. Screw through rige cap and top of each anchor clip. Pop Rivets can be used to anchor the ridge cap when using architectural or standing seam panels.

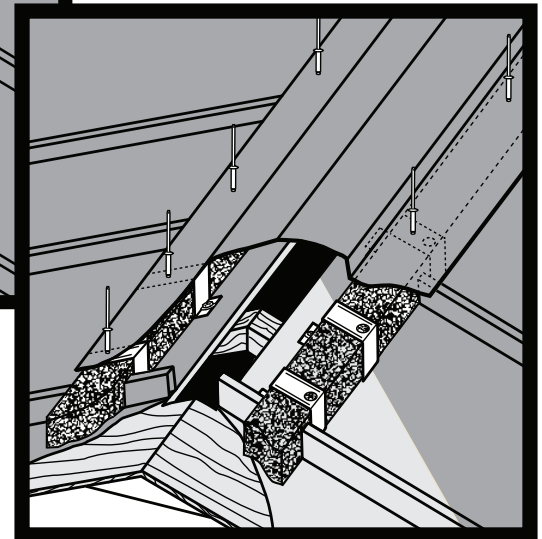

### TECHNICAL DATA

Passed	Net Free Area	1" nom. thickness	8.5 sq. in. per lin. ft. per slope (17 sq. in. per lin. fit. ridge)
Passed	Air Permeability	ASTM D737	>>760 cu. ft. per minute
Passed	Self-ignition Temp.	ASTM D1929	963°F
Passed	Cold Crack	Loren C115	Resistance to >-25°F
Passed	Snow Infiltration	CRL 5704	-0-
Passed	Tear Strength	ASTM D1294-86	Tear: Machine 25 p.p.i. Counter 25 p.p.i.
Passed	Tensile Strength	ASTM D2261-83	Tear: Machine 25 p.p.i. Counter 25 p.p.i.
Passed	Attic Dust Test	ASTM D1739-98	No Clogging, will not hold dust
Passed	Dust Exposure Test	ICBO AC132	
Passed	Loren	Compression	13%
		Recovery	100%
Passed	UV Stable	Chamber Test	No change to cover or materials
Passed	Abrasion Test	ASTM D1175	No damage to panel surface
Passed	100 MPH Wind Driven Rain Test		

NOTE 1: When ordering profile vent for panels that are striated use HW-116SL16 for Slimline®

NOTE 2: Use appropriate length fasteners to affix Ridge Cap through Profile Vent into Deck.  
Use Tri-Bead Tape Sealer at Profile Vent/Deck interface. DO NOT USE POP RIVETS.



**For the most current information available, visit [abcmetalroofing.com](http://abcmetalroofing.com) or call 877-713-6224.**